

Braided Categorical Quantum Mechanics I

Spencer D. Stirling^{*1,2,a} and Yong-Shi Wu^{†2,b}

¹Department of Mathematics, University of Utah

²Department of Physics and Astronomy, University of Utah

Summer 2009

Abstract

This is the first paper in a series where we generalize the Categorical Quantum Mechanics program (due to Abramsky, Coecke, et al [AC08]) to *braided systems*. In our view a uniform description of *quantum information* for braided systems has not yet emerged. The picture is complicated by a diversity of examples that lacks a unifying framework for proving theorems and discovering new protocols.

We use category theory to construct a high-level language that abstracts the quantum *mechanical* properties of braided systems. We exploit this framework to propose an axiomatic description of *braided quantum information* intended for topological quantum computation.

In this installment we first generalize the primordial Abramsky-Coecke “quantum information flow” paradigm from compact closed categories to right-rigid strict monoidal categories. We then study dagger structures for rigid and/or braided categories and formulate a graphical *dagger* calculus. We then propose two generalizations of strongly compact closed categories. Finally we study *partial traces* in the context of dagger categories.

*Corresponding author: stirling@math.utexas.edu

†wu@physics.utah.edu

Contents

1	Introduction	3
	Brief overview	5
2	Categorical Foundations	6
	(Strict) Monoidal Categories	6
	Rigid strict monoidal categories	13
	Technical lemmas	27
	Pivotal categories	28
	Quantum trace for pseudo-pivotal categories	31
	Quantum Information from Rigidity	33
	Braided strict monoidal categories	34
	Braided rigid strict monoidal categories	38
	Quantum trace for braided rigid categories	43
	Balanced Categories	44
	Balanced rigid strict monoidal categories	45
	Partial Trace	46
	Ribbon categories	48
3	Dagger Categories	52
	Dagger rigid strict monoidal categories	53
	Graphical dagger action	54
	Graphical dagger rigid strict monoidal categories	55
	Dagger braided strict monoidal categories	56
	Dagger braided rigid strict monoidal categories	59
	Unitary Type II theories	63
	Dagger balanced strict monoidal categories	63
	Dagger balanced rigid strict monoidal categories	64
	Dagger ribbon categories	66
4	Partial traces and dagger structures	69
	Goofy traces and tricks	70
	Type I partial traces	72
	Type II partial traces	75
5	Acknowledgements	75

1 Introduction

Over the past decade there has existed a program to reformulate the original von Neumann axioms of quantum mechanics in terms of category theory. Led by the efforts of Abramsky, Coecke, Selinger, Duncan, and others (see [AC08] and references therein), the goal has been to generalize the usual Hilbert space formulation to a “more economical” categorical language. ¹

Here “more economical” does not imply simpler - indeed the necessary background is much deeper and more abstract. However, the language is meant to distill the most important qualities shared by any system that may be called “quantum mechanical”. ² Ideas such as *state*, *evolution*, and *measurement* based on *physical* grounds were summarized in Dirac’s classic book [Dir82], and they were encoded in a list of mathematical axioms by von Neumann [vN96] (we also recommend [Mac04]). One advantage of *categorical* quantum mechanics is that these axioms - rather than being formulated from physical empirical observations - arise “for free” in the categorical context.

Abramsky, Coecke, and others have been chiefly motivated by ideas from *quantum information theory/computation*. These fields push the limits of quantum theory in the sense that they take the quantum axioms to their extreme logical conclusions - thereby providing both a testbed for von Neumann’s axioms as well as providing exciting practical applications.

The goals of this work are related but somewhat morphed. First, in view of the recent explosion of interest in *topological* quantum computation [SFN⁺07] it is crucial to bridge concepts from quantum information theory to condensed matter systems where the particles may be neither bosonic nor fermionic - but rather *anyonic*. Such particles (*effective* excitations, hence termed quasiparticles) obey *braiding statistics* [Wu84] and possibly provide a more robust method of quantum computation [Kit03].

Along these lines we endeavour to show that the braided categorical quantum mechanics program constructed here is a high-level language that provides a proper description of *braided quantum information* relevant to topological quantum computation.

Remark 1.1. The most promising physical candidate is the fractional quan-

¹We certainly do not advocate abandoning the customary Hilbert space formalism. The categorical language is meant to shed new light on an old subject.

²We emphasize that, in its current state, categorical quantum mechanics only provides a framework for *finitary* quantum mechanics, i.e. systems with state spaces that are finite-dimensional Hilbert spaces.

tum Hall effect, although very interesting developments in the *spin* fractional quantum Hall effect [KM05, BZ06], topological insulators [FKM07], and other strongly-correlated condensed matter systems may quickly attract the main focus.

Typically the common feature found in such systems is a (2+1)-dimensional conglomerate of strongly interacting fundamental particles (such as electrons in condensed matter systems, or atoms in an optical lattice). Under certain circumstances quantum mechanical effects can make the electrons coordinate - at a large distance scale - to produce quasiparticle excitations that behave distinctly from the constituent electrons.

By now it is well-known that many strongly correlated systems are described by *topological quantum field theories* [Ati90], [FHLT09].³ Considering this in addition to the link between topological quantum field theories and *modular tensor categories* [Tur94], [BK00], it is natural to build a bridge to the categorical quantum information program provided by Abramsky and Coecke.⁴

The second goal of this work is to show how our natural generalization to *braided* systems further justifies the “correctness” of the original categorical quantum mechanics program. In our view monoidal (or tensor) category theory is suitable for describing many-particle systems and, particularly, systems of identical particles. Since *statistics* is a fundamental quantum mechanical property of many-body systems we can utilize statistics as a testing ground for both ordinary and braided categorical quantum mechanics.

More precisely, in the Abramsky-Coecke formulation Bose-Einstein and Fermi-Dirac statistics are expected to be described by symmetric (ordinary) categorical quantum mechanics. More generally *braided statistics* theory for 2+1-dimensional systems was described in [Wu84] in terms of path integrals. We will later interpret braided statistics under the umbrella language of braided categorical quantum mechanics.

The final goal of this research is to formulate braided versions of the standard quantum information protocols such as *quantum teleportation* and

³Indeed the fractional quantum Hall effect can be explicitly transformed into an effective Chern-Simons theory. See for example section 5.16 in [Jai07]. Also see e.g. [Sti08] for a discussion concerning the relationship between Chern-Simons theories and topological quantum field theories.

⁴We note that the need for (and lack of) a connection between categorical quantum mechanics and topological quantum field theories was already mentioned in the conclusion of [AC08].

entanglement swapping and then calculate in braided examples. Given the dominance of *quantum groups* we shall study them using our new language of braided categorical quantum mechanics.

There are other examples that are also of physical interest. *Group categories* were studied in another context in [Sti08] and are examples of abelian braided systems. These examples are thought to be related to the well-known hierarchical states in the fractional quantum Hall effect, hence formulating group categories in the context of braided categorical quantum mechanics has immediate practical application.

Brief overview

This paper is the first installation in a series. In section (2) we begin with an overview of the categorical notions required for this work. Because some of the relevant literature is unpublished and/or incomplete we review several graphical calculi (due mainly to Joyal and Street) that are generalizations of the standard graphical calculus for ribbon categories. In particular we hope to provide a uniform discussion and also resist the temptation to limit our consideration to ribbon categories.

One main result of section (2) is that the Abramsky-Coecke “quantum information flow” construction generalizes from compact closed categories to right-rigid strict monoidal categories. This follows from the more general graphical calculi machinery, and it permits a foray into braided systems. The quantum information flow paradigm can be thought of as a primordial toolset upon which a more refined study of braided quantum information will be based in subsequent work.

In section (3) we study the interplay between dagger structures (Hermitian adjoint) and the various rigid, braided, balanced, and ribbon structures that are discussed in section (2). In particular we formulate two separate generalizations of the strongly compact closed categories that are used in ordinary categorical quantum mechanics. In addition we develop useful graphical *dagger* calculi for each of the categorical notions discussed in section (2).

Finally, in section (4) we study *partial traces* more closely. In particular we study how the dagger affects three different notions of partial trace which are canonically defined for balanced right-rigid strict monoidal categories.

2 Categorical Foundations

Rather than give a review of the standard von Neumann axioms of quantum mechanics we refer the reader to the first several sections of [AC08] and references therein. We shall also only give a brief review of *ordinary* categorical quantum mechanics when appropriate. We require a more elaborate categorical framework and graphical calculi (much of which can be difficult/impossible to find in the published literature), hence in this section we shall discuss these notions in sufficient detail. ⁵

The main result of this section is that we generalize the “quantum information flow” construction of Abramsky and Coecke from strongly compact closed categories to right-rigid strict monoidal categories. The Abramsky-Coecke quantum information flow paradigm can be viewed as a *primitive notion* of quantum information used in the subsequent complete description.

(Strict) Monoidal Categories

In ordinary quantum mechanics a composite system may be formed from two separate systems by taking the tensor product $H_1 \otimes H_2$ of the separate Hilbert spaces H_1 and H_2 . For *indistinguishable* bosons the tensor product is “symmetric”, i.e. we may permute the Hilbert spaces with no change in phase $H_1 \otimes H_2 \xrightarrow{\text{Perm}} H_2 \otimes H_1$. ⁶ Indistinguishable fermions are “antisymmetric” in the sense that we may permute the separate Hilbert spaces and pick up only an overall minus sign $H_1 \otimes H_2 \xrightarrow{\text{Perm}} -H_2 \otimes H_1$.

From a categorical perspective both bosons and fermions are called *symmetric* since $\text{Perm}^2 = \text{id}$. More general cases (see below) are *braided*, e.g. anyons may pick up complex phases that are not ± 1 (for *non-abelian* braiding the “phase change” is encoded in more complicated matrices).

We start by encoding the tensor product in the structure of a monoidal category. In this paper we shall restrict our attention to *strict* monoidal categories. The generalization to non-strict monoidal categories is straightfor-

⁵However the graphical calculus for ribbon categories is exhaustively documented [Tur94], [BK00] and we do not reproduce it here.

⁶Physically this means we may adiabatically (slowly) exchange the particles around one another. Since the final configuration is identical to the original configuration the state/wavefunction cannot change. However wavefunctions are only defined up to an overall phase. For bosons it happens that the overall phase does not change under this operation.

ward. We warn the reader that in actual computations a non-strict category may be necessary (see, for example, [Sti08]). For notational conventions and more details we refer the reader to Chapter 4 in [Sti08].

Definition 2.1. A **strict monoidal category** is a category \mathcal{V} equipped with a covariant bifunctor $\otimes : \mathcal{V} \times \mathcal{V} \rightarrow \mathcal{V}$ and a distinguished object $\mathbb{1}$ such that the following two identities hold:

1. Strict identity:

$$U \otimes \mathbb{1} = \mathbb{1} \otimes U = U \tag{2.4}$$

2. Strict associativity:

$$(U \otimes V) \otimes W = U \otimes (V \otimes W) \tag{2.5}$$

Example 2.6. A simple example of a strict monoidal category is the category $\text{Vect}_{\mathbb{C}}$ of complex vector spaces under the usual tensor product. Here the unit object is $\mathbb{1} = \mathbb{C}$.

Definition 2.7. Scalar multiplication is well-defined in a monoidal category. The scalars are identified with the set $\text{Hom}(\mathbb{1}, \mathbb{1})$ in the following way: given an object $V \in \text{Ob}(\mathcal{V})$ we may multiply by a morphism $s : \mathbb{1} \rightarrow \mathbb{1}$ (a scalar) using the monoidal structure ⁸

$$V \xrightarrow{\sim} \mathbb{1} \otimes V \xrightarrow{s \otimes \text{id}_V} \mathbb{1} \otimes V \xrightarrow{\sim} V \tag{2.8}$$

Following [AC08] we denote this morphism

$$s \bullet V : V \xrightarrow{\sim} V \tag{2.9}$$

⁷By *covariant bifunctor* we mean that for any two objects $V, W \in \text{Ob}(\mathcal{V})$ there is an object $V \otimes W \in \text{Ob}(\mathcal{V})$, and for any two morphisms $f : V \rightarrow V'$ and $g : W \rightarrow W'$ there is a morphism $f \otimes g : V \otimes W \rightarrow V' \otimes W'$. Functoriality means that given morphisms $f' : V' \rightarrow V''$, $g' : W' \rightarrow W''$ the following identities are required to be satisfied:

$$(f' \circ f) \otimes (g' \circ g) = (f' \otimes g') \circ (f \otimes g) \tag{2.2}$$

$$\text{id}_V \otimes \text{id}_W = \text{id}_{V \otimes W} \tag{2.3}$$

⁸The first and last isomorphisms use the left unit $l_V : \mathbb{1} \otimes V \xrightarrow{\sim} V$ if we wish to consider non-strict monoidal categories.

We may also multiply morphisms $f : V \rightarrow W$

$$s \bullet f := f \circ (s \bullet V) = (s \bullet W) \circ f \quad (2.10)$$

In this definition we have already implied that scalar multiplication s is *natural*, i.e. the following diagram commutes (this follows from the naturality of the left unit family of isomorphisms $l_V : \mathbb{1} \otimes V \xrightarrow{\sim} V$):

$$\begin{array}{ccc} V & \xrightarrow{s \bullet V} & V \\ \downarrow f & & \downarrow f \\ W & \xrightarrow{s \bullet W} & W \end{array} \quad (2.11)$$

We may define “right scalar multiplication” $V \bullet s : V \xrightarrow{\sim} V$ similarly as the morphism

$$V \xrightarrow{\sim} V \otimes \mathbb{1} \xrightarrow{\text{id}_V \otimes s} V \otimes \mathbb{1} \xrightarrow{\sim} V \quad (2.12)$$

We shall restrict our attention to left scalar multiplication. ⁹

It was pointed out by Kelly and Laplaza [KL80] that scalars $s, t \in \text{Hom}(\mathbb{1}, \mathbb{1})$ commute (i.e. $s \circ t = t \circ s$) if the category is monoidal. For convenience we copy from [AC08] properties that \bullet satisfies, all of which can be proven from the monoidal structure alone (here $1 := \text{id}_{\mathbb{1}}$):

$$\begin{aligned} 1 \bullet f &= f & (2.13) \\ s \bullet (t \bullet f) &= t \bullet (s \bullet f) = (s \circ t) \bullet f \\ (s \bullet g) \circ (t \bullet f) &= s \bullet (t \bullet (g \circ f)) \\ (s \bullet f) \otimes (t \bullet g) &= s \bullet (t \bullet (f \otimes g)) \end{aligned}$$

For example in the category of finite-dimensional complex vector spaces $\text{Vect}_{\mathbb{C}}$ it is clear that scalar multiplication is given by 1×1 complex matrices

$$z : \mathbb{1} = \mathbb{C} \rightarrow \mathbb{1} = \mathbb{C} \quad (2.14)$$

⁹If the category is braided then it is easy to show that $s \bullet V = V \bullet s$. In a non-strict category (for concreteness) the left and right unit isomorphisms $l_V : \mathbb{1} \otimes V \xrightarrow{\sim} V$ and $r_V : V \otimes \mathbb{1} \xrightarrow{\sim} V$ satisfy the equation $l_V^{-1} \circ r_V = c_{V, \mathbb{1}} : V \otimes \mathbb{1} \xrightarrow{\sim} \mathbb{1} \otimes V$ where c is the braiding (see e.g. Section 2 in [JS93]). Hence, by naturality of c we have $(l_V^{-1} \circ r_V) \circ (\text{id}_V \otimes s) = (s \otimes \text{id}_V) \circ (l_V^{-1} \circ r_V)$. Then the statement follows easily.

Example 2.15. ProgPlanar_I: We now construct a more elaborate (and geometric) example due to Joyal and Street of a strict monoidal category [JS91a], [JS91b], [JS88].¹⁰ Let I be a labelling set of “colors”. We want to define the category ProgPlanar_I of **progressive planar diagrams**. First we require some preliminary notions.

Definition 2.16. A (k, l) -**progressive planar graph between levels a and b** consists of a compact Hausdorff space embedded in the strip $\mathbb{R} \times [a, b] \subset \mathbb{R}^2$. It is constructed from finitely-many of the following elementary pieces (see figure (1)):

1. “Vertical” *smooth line segments*
2. *Coupons* (horizontal rectangular strips)

By a “vertical” line segment we mean that at any point along the segment the tangent line is *not* horizontal.

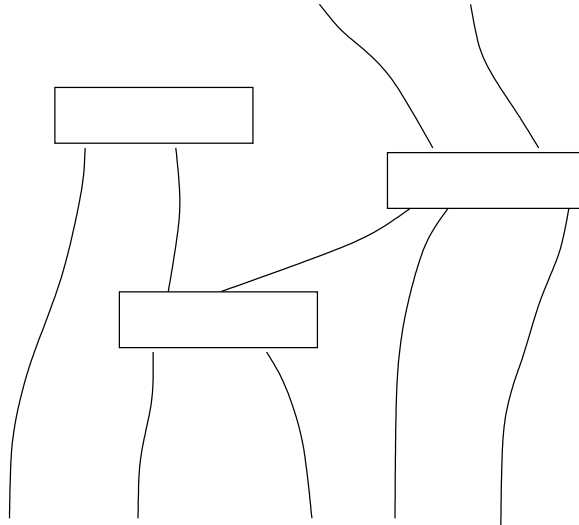

Figure 1: A $(k = 5, l = 2)$ -progressive planar graph.

Coupons are not allowed to intersect the top $\mathbb{R} \times \{b\}$ nor the bottom $\mathbb{R} \times \{a\}$ of the ambient strip $\mathbb{R} \times [a, b]$. Coupons are always rectangular and

¹⁰The construction described here is a slight modification of that from Joyal and Street. However the main features are nearly identical.

the tops and bottoms (of the coupons) must remain parallel with the top and bottom of the ambient strip $\mathbb{R} \times [a, b]$. The graph should be thought of as “evolving” from the bottom to the top. The elementary pieces are not allowed to intersect except at a finite number of points which we now describe.

Each coupon has a distinguished bottom side (“in”) and distinguished top side (“out”). Line segments are allowed to terminate at isolated points on these “in” and “out” sides. Line segments can also terminate at k isolated points on the bottom of the ambient strip $\mathbb{R} \times \{a\}$ - these are called **inputs**. Likewise line segments can terminate at l isolated points on the top of the ambient strip $\mathbb{R} \times \{b\}$ (called **outputs**). Line segments are not allowed to terminate elsewhere (i.e. no “floating” endpoints).

We want to consider (k, l) -progressive planar graphs only up to **progressive isotopies** - these are smooth isotopies of the strip $\mathbb{R} \times [a, b]$ subject to the following restrictions:

1. Line segments must always remain “vertical”
2. Coupons must always remain coupons (see restrictions above).

Clearly under isotopy of the strip the k inputs must always remain on the bottom $\mathbb{R} \times \{a\}$ of the strip. Although they are allowed to slide, the ordering must be preserved. Similar statements are true for the l outputs. We note that the progressive condition implies that line segments cannot slide from the “in” side to the “out” side of a coupon (or vica versa) under progressive isotopy.

Now let I be a set of labels (colors). We define a **colored (k, l) -progressive planar graph** as a (k, l) -progressive planar graph where each line segment is labelled by some element in I (we do not color the coupons yet).

Definition 2.17. Define a strict monoidal category ProgPlanar_I as follows:

1. The objects are ordered lists $[[i_1], [i_2], \dots]$ where $i_1, i_2, \dots \in I$. The unit object $\mathbb{1}$ is the empty list $[\]$.
2. Given objects $[[i_1], [i_2], \dots, [i_k]]$ and $[[i'_1], [i'_2], \dots, [i'_l]]$ a morphism between them is a colored (k, l) -progressive planar graph (up to progressive isotopy) such that the k “input” line segments are labelled (in order) by i_1, \dots, i_k and similiary the l “output” line segments are labelled by i'_1, \dots, i'_l . It is obvious that these morphisms can be composed by stacking colored graphs on top of each other.

ProgPlanar_I is a strict monoidal category since any two ordered lists can be concatenated

$$[[i_1], [i_2], \dots, [i_k]] \otimes [[i'_1], [i'_2], \dots, [i'_l]] = [[i_1], [i_2], \dots, [i_k], [i'_1], [i'_2], \dots, [i'_l]] \quad (2.18)$$

(this defines \otimes on the objects) and graphs can be placed adjacent to each other (this defines \otimes on the morphisms).

Example 2.19. $\text{ProgPlanar}_{\mathcal{V}}$: The previous example becomes more interesting if we change the labelling set I to a predefined strict monoidal category \mathcal{V} (we label all line segments with *objects* in \mathcal{V}). In this situation we have two distinct strict monoidal categories: $\text{ProgPlanar}_{\mathcal{V}}$ and \mathcal{V} itself. We wish to use $\text{ProgPlanar}_{\mathcal{V}}$ to perform graphical computations that are meaningful in \mathcal{V} (i.e. we seek a **graphical calculus**). In its current form $\text{ProgPlanar}_{\mathcal{V}}$ is not yet suitable, however we can extend it so that such computations are meaningful.

Consider an elementary piece of a graph as depicted in figure (2). Because of the monoidal structure on \mathcal{V} it makes sense to color the *coupon* with a morphism $f : V_1 \otimes \dots \otimes V_k \rightarrow W_1 \otimes \dots \otimes W_l$. We denote this as \boxed{f} .

If all *coupons* in a colored (k, l) -progressive planar graph are colored with appropriate morphisms in \mathcal{V} then we say that the graph is a **fully colored (k, l) -progressive planar graph**. We will assume from now on that all morphisms in $\text{ProgPlanar}_{\mathcal{V}}$ are fully colored.

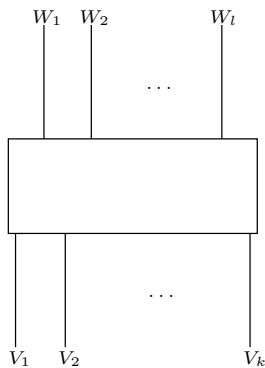

Figure 2: An elementary colored (k, l) -progressive planar graph.

We must also extend our notion of progressive planar isotopy to allow for the additional moves depicted in figure (3).

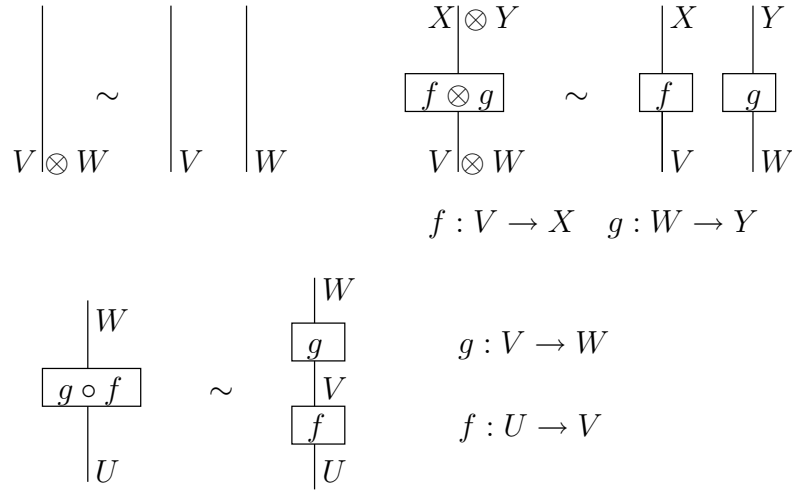

Figure 3: Additional *progressive planar isotopy* moves that are allowed if the coloring set is a strict monoidal category \mathcal{V} .

$\text{ProgPlanar}_{\mathcal{V}}$ provides a graphical calculus for \mathcal{V} because of the following theorem due to Joyal and Street [JS91a]:¹¹

Theorem 2.20 (Joyal, Street). *Let \mathcal{V} be a **strict** monoidal category. Consider the **strict** monoidal category $\text{ProgPlanar}_{\mathcal{V}}$. Denote by $|_V$ a vertical line segment colored by an object $V \in \text{Ob}(\mathcal{V})$. Then there is a unique monoidal¹² functor*

$$F : \text{ProgPlanar}_{\mathcal{V}} \rightarrow \mathcal{V} \tag{2.21}$$

such that

$$\begin{aligned} F(|_V|) &= V \\ F(|_V|) &= id_V \\ F(\boxed{f}) &= f \end{aligned} \tag{2.22}$$

Informally we say that the functor F associates to any appropriate “picture” a morphism in \mathcal{V} . If any two pictures are progressively isotopic then their corresponding morphisms in \mathcal{V} are *equal* (even though they may algebraically appear unrelated).

¹¹We have modified the language of the theorem. Joyal and Street prove that the *value* (not defined here) of a fully colored (k, l) -progressive planar graph is invariant under *progressive* isotopies.

¹²See (for example) [JS93] for the definition of monoidal functor.

Rigid strict monoidal categories

In Abramsky and Coecke [AC08] *compact closed* categories are considered as the primitive structure appropriate for finitary quantum mechanics. These are *symmetric* monoidal categories equipped with a left rigidity structure (see below).¹³ We wish to be more general, so we dispense with symmetric (and we shall use *right* rigidity¹⁴ to maintain contact with our previous work).

Definition 2.23. A **right-rigid strict monoidal category** \mathcal{V} is a strict monoidal category such that for each object $V \in \text{Ob}(\mathcal{V})$ there is a distinguished **right dual** object V^* and morphisms (*not necessarily isomorphisms*)

$$\begin{aligned} b_V &: \mathbb{1} \rightarrow V \otimes V^* \\ d_V &: V^* \otimes V \rightarrow \mathbb{1} \end{aligned} \tag{2.24}$$

These are *birth* and *death* morphisms. In addition we require that the following maps must be equal to id_V and id_{V^*} , respectively:

$$\begin{aligned} V &\xrightarrow{b_V \otimes \text{id}_V} V \otimes V^* \otimes V \xrightarrow{\text{id}_V \otimes d_V} V \\ V^* &\xrightarrow{\text{id}_{V^*} \otimes b_V} V^* \otimes V \otimes V^* \xrightarrow{d_V \otimes \text{id}_{V^*}} V^* \end{aligned} \tag{2.25}$$

As a preview we mention that a graphical calculus for rigid¹⁵ strict monoidal categories was constructed by Joyal and Street in [JS88]. Later we describe a slightly *constrained* graphical calculus that applies to **right-rigid** strict monoidal categories.¹⁶ The picture that corresponds to equation (2.25) is depicted in figure (4). We note that for right-rigid categories there are *not necessarily* canonical isomorphisms $V \xrightarrow{\sim} V^{**}$. We also note that right rigidity is unique up to unique isomorphism (i.e. there is a “right-rigid version” of proposition (2.29) below - see also section 2.1 in [BK00]).¹⁷

¹³We note that the graphical calculus used in [AC08] is justified because compact closed categories are trivially *ribbon categories* (see below): since they are symmetric (trivial braiding) the *twist* isomorphisms are just id_V for each $V \in \text{Ob}(\mathcal{V})$. Then the graphical calculus described in detail in [Tur94] for ribbon categories is appropriate. In the following we discuss more general graphical calculi (studied by Joyal and Street in a paper and several unpublished notes) that apply to more general categories.

¹⁴Often called left autonomous in other literature.

¹⁵Rigid categories are categories that are *both* right and left rigid (see below).

¹⁶There is an analogous constrained graphical calculus for left-rigid strict monoidal categories that we describe.

¹⁷In particular uniqueness up to unique isomorphism implies that $\mathbb{1}^* = \mathbb{1}$ and $(V \otimes W)^* =$

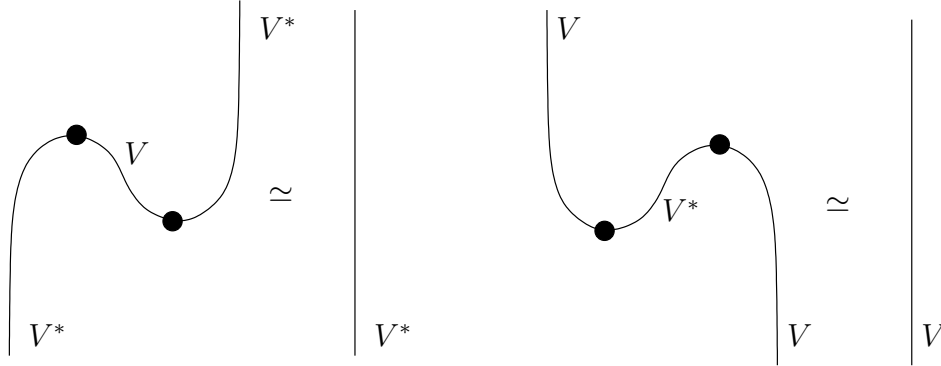

Figure 4: Right-rigidity condition in $\text{PolarPlanar}_V^{\text{Right}}$.

Definition 2.26. A **left-rigid strict monoidal category** \mathcal{V} is a strict monoidal category such that for each object $V \in \text{Ob}(\mathcal{V})$ there is a distinguished **left dual** object V^\vee and morphisms (*not necessarily isomorphisms*)

$$\begin{aligned} \beta_V : \mathbb{1} &\rightarrow V^\vee \otimes V \\ \delta_V : V \otimes V^\vee &\rightarrow \mathbb{1} \end{aligned} \quad (2.27)$$

These are *birth* and *death* morphisms. In addition we require that the following maps must be equal to id_V and id_{V^\vee} , respectively:

$$\begin{aligned} V &\xrightarrow{\text{id}_V \otimes \beta_V} V \otimes V^\vee \otimes V \xrightarrow{\delta_V \otimes \text{id}_V} V \\ V^\vee &\xrightarrow{\beta_V \otimes \text{id}_{V^\vee}} V^\vee \otimes V \otimes V^\vee \xrightarrow{\text{id}_{V^\vee} \otimes \delta_V} V^\vee \end{aligned} \quad (2.28)$$

The picture that corresponds to equation (2.28) is depicted in figure (5). Similarly for left-rigid categories there are *not necessarily* canonical isomorphisms $V \xrightarrow{\sim} V^{\vee\vee}$. Left rigidity is unique up to unique isomorphism (see proposition (2.29) next).¹⁸

According to the next proposition left-rigidity is essentially unique [BK00] (a similar proposition holds for right-rigid categories). We note that “strictness” is not necessary.

$W^* \otimes V^*$ (we abuse “equality” here to mean unique up to unique isomorphism - however we must be careful because such abuse can lead to wrong conclusions. See remark (2.45) for example).

¹⁸In particular this implies that $\mathbb{1}^\vee = \mathbb{1}$ and $(V \otimes W)^\vee = W^\vee \otimes V^\vee$ (again we abuse “equality” here).

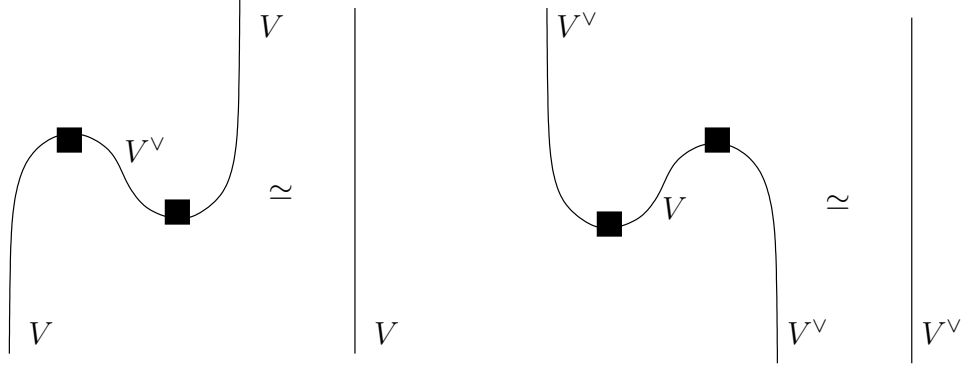

Figure 5: Left-rigidity condition in $\text{PolarPlanar}_V^{\text{Left}}$.

Proposition 2.29. *Let \mathcal{V} be a left-rigid strict monoidal category with left dual V^\vee for any object V . Suppose there exists another left rigidity structure $V^{\vee'}$ with birth and death morphisms β'_V and δ'_V . Then there exists a family of **unique** natural isomorphisms (one for each object V) $\varphi_V : V^{\vee'} \xrightarrow{\sim} V^\vee$ such that the following diagrams commute*

$$\begin{array}{ccc}
 V^{\vee'} \otimes V & \xrightarrow{\varphi_V \otimes \text{id}_V} & V^\vee \otimes V \\
 \beta'_V \swarrow & & \nearrow \beta_V \\
 & \mathbb{1} &
 \end{array} \quad (2.30)$$

$$\begin{array}{ccc}
 V \otimes V^{\vee'} & \xrightarrow{\text{id}_V \otimes \varphi_V} & V \otimes V^\vee \\
 \delta'_V \swarrow & & \searrow \delta_V \\
 & \mathbb{1} &
 \end{array} \quad (2.31)$$

Proof. Define φ_V as the canonical morphism

$$V^{\vee'} \xrightarrow{\beta_V \otimes \text{id}_{V^{\vee'}}} V^\vee \otimes V \otimes V^{\vee'} \xrightarrow{\text{id}_{V^\vee} \otimes \delta'_V} V^\vee \quad (2.32)$$

It is easy to show that this is an *isomorphism* by finding an inverse. Uniqueness is also straightforward. The graphical calculus described below may be helpful, although it is not necessary.

Finally, for naturality we need to show that the following diagram com-

mutates given any morphism $f : V \rightarrow W$:

$$\begin{array}{ccc}
 V^{V'} & \xrightarrow{\varphi_V} & V^V \\
 f^{V'} \uparrow & & \uparrow f^V \\
 W^{V'} & \xrightarrow{\varphi_W} & W^V
 \end{array} \tag{2.33}$$

This is left to the reader, although we mention that the dual maps f^V and $f^{V'}$ have not been defined yet - they are defined similarly to how f^* is defined below. \square

Remark 2.34. Warning: the isomorphism φ_V in the previous proposition is *not* monoidal, i.e. it is not true that $\varphi_{V \otimes W} \stackrel{?}{=} \varphi_V \otimes \varphi_W$ (for example up to unique isomorphism it is easy to verify that $(V \otimes W)^V = W^V \otimes V^V$). Another example is given in corollary (2.111).

We require some more definitions that apply to any right-rigid strict monoidal category. There are analogous definitions for left-rigid strict monoidal categories - we encourage the reader to write out the appropriate constructions.

Definition 2.35. For any right-rigid strict monoidal category \mathcal{V} consider a morphism $f : V \rightarrow W$. We define the **name of f** (denoted $\check{f} : \mathbb{1} \rightarrow W \otimes V^*$) by the commutative diagram

$$\begin{array}{ccc}
 V \otimes V^* & \xrightarrow{f \otimes \text{id}_{V^*}} & W \otimes V^* \\
 b_V \uparrow & \nearrow \check{f} & \\
 \mathbb{1} & &
 \end{array} \tag{2.36}$$

Following Abramsky and Coecke we use the triangle notation as in the left side of figure (6).

Definition 2.37. Similarly, for any right-rigid strict monoidal category \mathcal{V} and morphism $f : V \rightarrow W$ we can define the **coname of f** (denoted $\hat{f} :$

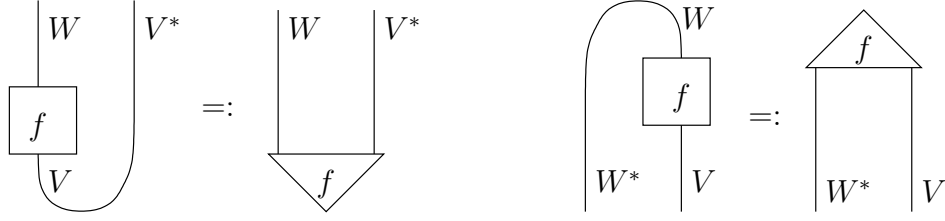

Figure 6: \check{f} and \hat{f} (name and coname) and corresponding notation

$W^* \otimes V \rightarrow \mathbb{1}$) by the commutative diagram

$$\begin{array}{ccc}
 & & \mathbb{1} \\
 & \nearrow \hat{f} & \uparrow d_W \\
 W^* \otimes V & \xrightarrow{\text{id}_{W^*} \otimes f} & W^* \otimes W
 \end{array} \tag{2.38}$$

This is depicted on the right side of figure (6).

Definition 2.39. Finally, for any right-rigid strict monoidal category \mathcal{V} any morphism $f : V \rightarrow W$ induces a **right dual morphism** $f^* : W^* \rightarrow V^*$ (sometimes called a **transpose**) defined by

$$W^* \xrightarrow{\text{id}_{W^*} \otimes b_V} W^* \otimes V \otimes V^* \xrightarrow{\text{id}_{W^*} \otimes f \otimes \text{id}_{V^*}} W^* \otimes W \otimes V^* \xrightarrow{d_W \otimes \text{id}_{V^*}} V^* \tag{2.40}$$

An illuminating picture can be easily drawn and is left to the reader.

Definition 2.41. A **rigid strict monoidal category** is a strict monoidal category that is both left and right rigid.

As mentioned there are *not* (in general) canonical isomorphisms $V \xrightarrow{\sim} V^{**}$ or $V \xrightarrow{\sim} V^{\vee\vee}$ for right and left rigid categories, respectively. However, for rigid categories the following facts are true (again strictness is not necessary):

Lemma 2.42. *If \mathcal{V} is a rigid strict monoidal category then there exist canonical **natural** isomorphisms*

$$p_V : V \xrightarrow{\sim} (V^*)^\vee \quad \text{and} \quad q_V : V \xrightarrow{\sim} (V^\vee)^* \tag{2.43}$$

Proof. We sketch the idea of the proof in terms of pictures. Although this approach is (for now) unjustified, it is a straightforward exercise to translate the following into algebraic statements (the pictures progress from bottom to top). We only use the rigidity conditions in equations (2.25) and (2.28).

We only construct the first isomorphism since the second is similar. First we introduce the graphical depictions of the birth and death morphisms in figure (7).

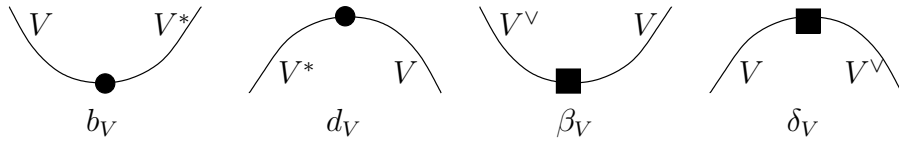

Figure 7: Birth and death morphisms in $\text{PolarPlanar}_V^{\text{Right}}$ and $\text{PolarPlanar}_V^{\text{Left}}$.

Consider the morphisms $V \rightarrow (V^*)^\vee$ and $(V^*)^\vee \rightarrow V$ given in figure (8) (utilizing d_V and β_{V^*} in the left morphism and δ_{V^*} and b_V in the right morphism).

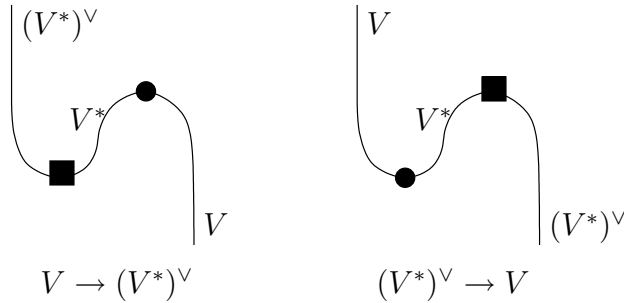

Figure 8: Isomorphisms that can be stacked in either order to isotope to the identity

If we stack the second picture on top of the first (and then use equations (2.25) and (2.28)) we obtain id_V . Likewise if we stack the first picture on top of the second and use the same rigidity conditions then we obtain $\text{id}_{(V^*)^\vee}$. Hence both of these morphisms are inverses of each other, hence providing a canonical isomorphism $V \xrightarrow{\sim} (V^*)^\vee$.

Naturality is straightforward to prove and left to the reader (start with pictures, then translate into rigorous algebraic statements). We merely need

to show that given any morphism $f : V \rightarrow W$ the following diagram commutes:

$$\begin{array}{ccc} V & \xrightarrow{\sim} & (V^*)^\vee \\ \downarrow f & & \downarrow (f^*)^\vee \\ W & \xrightarrow{\sim} & (W^*)^\vee \end{array} \quad (2.44)$$

□

Remark 2.45. Warning: The isomorphisms p_V and q_V described in the previous lemma (2.42) are *not monoidal* (e.g. it is not necessarily true that $p_{V \otimes W} \stackrel{?}{=} p_V \otimes p_W$, and likewise for q_V). Even if $V^\vee = V^*$ for every object V we still cannot conclude this (for a counterexample see the rigidity structure described in proposition (2.105)).

This can be confusing since we have remarked that “ $(V \otimes W)^* = W^* \otimes V^*$ ” and likewise “ $(V \otimes W)^\vee = W^\vee \otimes V^\vee$ ”. Let us restrict our attention (for example) to the case where $V^\vee = V^*$ for every object V . Then we have “ $(V \otimes W)^* = W^* \otimes V^* = W^\vee \otimes V^\vee = (V \otimes W)^\vee$ ”. Hence we might be tempted to use reasoning as in figure (9) (we utilize the graphical calculus PolarPlanary described below).

The problem is that “equality” is abusive. This example shows that the unique isomorphisms described in proposition (2.29) (and the analogous right-rigid proposition) must be handled explicitly. To study $p_{V \otimes W}$ let us give notation to the unique isomorphisms that we will need:

$$\begin{aligned} \phi_{V \otimes W} &: W^* \otimes V^* \xrightarrow{\sim} (V \otimes W)^* & (2.46) \\ \varphi_{V \otimes W} &: W^\vee \otimes V^\vee \xrightarrow{\sim} (V \otimes W)^\vee \\ \varphi_{V \otimes W}^\vee &: (V \otimes W)^{\vee\vee} \xrightarrow{\sim} (W^\vee \otimes V^\vee)^\vee \\ (\varphi_{V \otimes W}^\vee)^{-1} &: (W^\vee \otimes V^\vee)^\vee \xrightarrow{\sim} (V \otimes W)^{\vee\vee} \\ \varphi_{W^\vee \otimes V^\vee} &: V^{\vee\vee} \otimes W^{\vee\vee} \xrightarrow{\sim} (W^\vee \otimes V^\vee)^\vee \end{aligned}$$

Using these unique isomorphisms we rewrite $\beta_{(V \otimes W)^\vee}$ as in figure (11) (the first \sim is easily verified using figure (10)). Likewise we rewrite $d_{V \otimes W}$ in figure (12).

Since we are assuming (for example) that $V^* = V^\vee$ for all objects V we have in particular that $(V \otimes W)^\vee = (V \otimes W)^*$, hence it makes sense to glue the right-most diagrams in figures (11) and (12) together to form

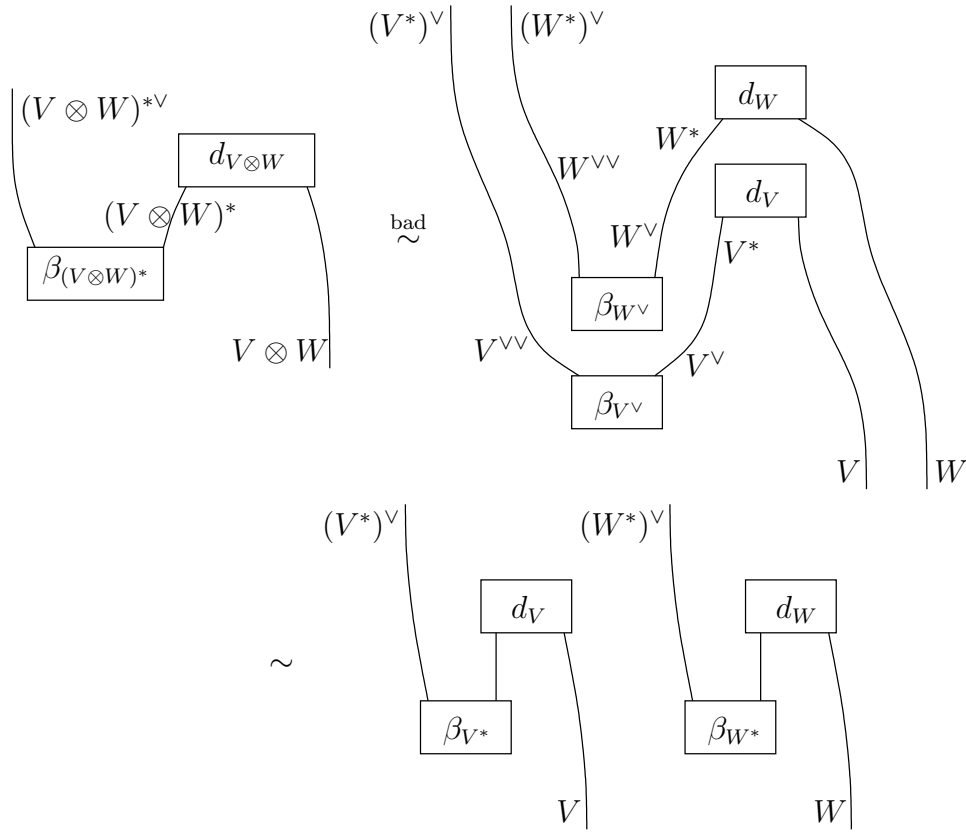

Figure 9: Incorrect reasoning that “concludes” that $p_{V \otimes W} = p_V \otimes p_W$.

the isomorphism p_V . We see that even under these assumptions we *cannot* conclude that p_V is monoidal without further assumptions on φ and ϕ .

Definition 2.47. Given a right-rigid strict monoidal category \mathcal{V} we define a functor $(\)^* : \mathcal{V}^{\text{op}} \rightarrow \mathcal{V}$ that sends $V \mapsto V^*$ and $\{f : V \rightarrow W\} \mapsto \{f^* : W^* \rightarrow V^*\}$.

Definition 2.48. Given a left-rigid strict monoidal category \mathcal{V} we define a functor $(\)^\vee : \mathcal{V}^{\text{op}} \rightarrow \mathcal{V}$ that sends $V \mapsto V^\vee$ and $\{f : V \rightarrow W\} \mapsto \{f^\vee : W^\vee \rightarrow V^\vee\}$.

The following lemma has a left-rigid version that we leave to the reader to formulate. We refer the reader to Chapter 2 of [JS91b] for other elaborations.

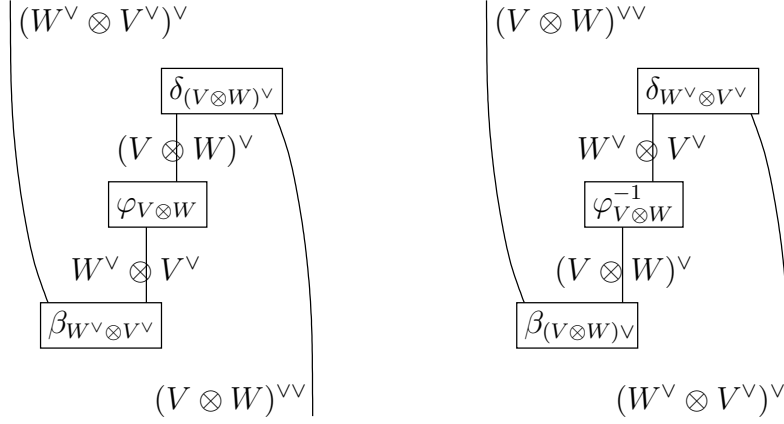

Figure 10: On the left we depict $\varphi_{V \otimes W}^v$ and on the right we depict $(\varphi_{V \otimes W}^v)^{-1}$.

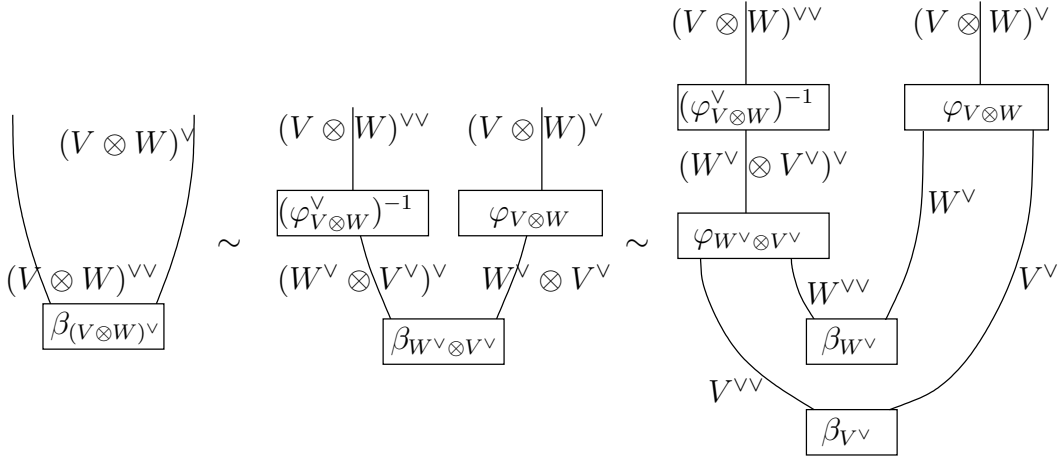

Figure 11: Rewriting $\beta_{(V \otimes W)^v}$ using the unique isomorphisms denoted in equation (2.46).

Lemma 2.49. *Let \mathcal{V} be a right-rigid strict monoidal category. Then $(\)^*$ is a **fully faithful monoidal** functor. Furthermore $(\)^*$ defines an equivalence (in fact a monoidal equivalence) of categories if and only if \mathcal{V} is also left-rigid.*

Proof. It is straightforward to show that $(\)^* : \mathcal{V}^{\text{op}} \rightarrow \mathcal{V}$ is a monoidal functor and is always full and faithful.

It is also an exercise to show that if a monoidal functor defines an equiva-

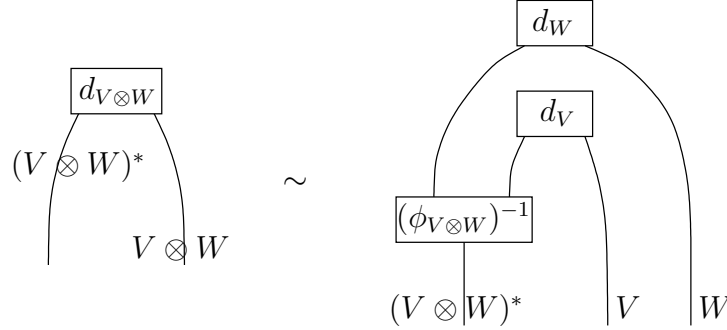

Figure 12: Rewriting $d_{V \otimes W}$ using the unique isomorphisms denoted in equation (2.46).

lence¹⁹ then it defines a *monoidal* equivalence. Hence (since $()^*$ is monoidal) we do not have to worry about “monoidal” in any of the following equivalences since it is automatic.

We prove one direction: assume \mathcal{V} is a rigid strict monoidal category. We want to show that the functor $()^* : \mathcal{V}^{\text{op}} \rightarrow \mathcal{V}$ defines an equivalence of categories. We note that an equivalence of categories is the same as the existence of a fully faithful essentially surjective²⁰ functor (c.f. [Kas95] Proposition XI.1.5). We already have that $()^*$ is fully faithful. It remains to prove that $()^*$ is essentially surjective.

According to lemma (2.42) in a rigid strict monoidal category we have canonical natural isomorphisms $V \xrightarrow{\sim} (V^*)^\vee$ and $V \xrightarrow{\sim} (V^\vee)^*$. Hence V is isomorphic to the right dual of some object, namely $V \cong (V^\vee)^*$. This proves that $()^*$ is essentially surjective. We conclude that $()^* : \mathcal{V}^{\text{op}} \rightarrow \mathcal{V}$ defines an equivalence of categories.

To prove the other direction we assume that \mathcal{V} is a right-rigid strict monoidal category and that $()^*$ defines an equivalence of categories. So $()^*$ is essentially surjective, i.e. there exists an isomorphism $q_V : V \xrightarrow{\sim} (A)^*$ for some object A . We set $V^\vee := A$, $\beta_V := (\text{id}_A \otimes q_V^{-1}) \circ b_A$, and $\delta_V := d_A \circ (q_V \otimes \text{id}_A)$. This proves that \mathcal{V} is left-rigid as well. \square

Example 2.50. PolarPlanar $_{\mathcal{V}}^{\text{Right}}$: Let \mathcal{V} be a predefined right-rigid strict monoidal category. We now wish to construct a geometric right-rigid strict

¹⁹Here we mean ordinary equivalence as categories.

²⁰A functor $F : \mathcal{V} \rightarrow \mathcal{V}'$ is *essentially surjective* if every object $V' \in \text{Ob}(\mathcal{V}')$ is isomorphic to some object $F(V)$ in the image of F .

monoidal category $\text{PolarPlanar}_{\mathcal{V}}^{\text{Right}}$ that will serve as a graphical calculus for \mathcal{V} .

Definition 2.51. A **right (k, l) -polarised planar graph between levels a and b** is a (k, l) -progressive planar graph between levels a and b that has two distinguished types of coupons (see figure (13)):

1. Isolated maxima/minima denoted by \bullet as in the left side of figure (7) (we ignore the labelling of the segments for now).

We note that *not all coupons* that have two line segments on the bottom (“in”) and zero line segments on the top (“out”) are maxima (i.e. not all such coupons are distinguished). A similar statement holds for minima versus coupons that superficially look like minima.

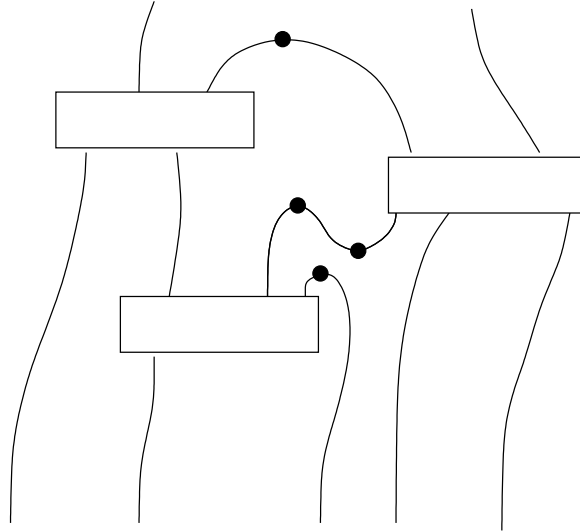

Figure 13: A $(k = 5, l = 2)$ -polarised planar graph.

We want to consider right (k, l) -polarised planar graphs only up to **right-polarised isotopies**. A right-polarised isotopy is a progressive isotopy of the underlying (k, l) -progressive planar graph equipped with the following additional moves (we ignore any labelling of the segments for now):

1. Maxima/minima pairs \bullet are allowed to collide and annihilate as in figure (4) (changing 3 vertical line segments into a single vertical line segment).

2. Maxima/minima pairs \bullet can be created at any point on a vertical line segment as in figure (4) (changing a single vertical line segment into 3 vertical line segments).

We define a **fully colored right (k, l) -polarised planar graph** as a right (k, l) -polarised planar graph where each vertical line segment is labelled by an object in \mathcal{V} and each coupon is labelled by an appropriate morphism. In addition we enforce:

1. The objects labelling the line segments attached to maxima/minima \bullet are required to obey the compatibility rules depicted on the left side of figure (7).
2. We may always switch notation between a maxima (minima) and a coupon labelled with the appropriate death morphism \boxed{d} (birth morphism \boxed{b}), respectively.

Definition 2.52. Define a right-rigid strict monoidal category $\text{PolarPlanar}_{\mathcal{V}}^{\text{Right}}$ as follows:

1. The objects are ordered lists $[[V_1], [V_2], \dots]$ where $V_1, V_2, \dots \in \text{Ob}(\mathcal{V})$. The unit object $\mathbb{1}$ is the empty list $[\]$.
2. Given objects $[[V_1], [V_2], \dots, [V_k]]$ and $[[W_1], [W_2], \dots, [W_l]]$ a morphism between them is a fully colored right (k, l) -polarised planar graph (up to right-polarised isotopy) such that the k “input” line segments are labelled (in order) by V_1, \dots, V_k and similiary the l “output” line segments are labelled by W_1, \dots, W_l . It is obvious that these morphisms can be composed by stacking colored graphs on top of each other.

$\text{PolarPlanar}_{\mathcal{V}}^{\text{Right}}$ is a strict monoidal category in the same way that $\text{ProgPlanar}_{\mathcal{V}}$ is. More interestingly, $\text{PolarPlanar}_{\mathcal{V}}^{\text{Right}}$ is a right-rigid strict monoidal category because equation (2.25) is enforced by the additional moves described in the definition of *right-polarised isotopy*.

$\text{PolarPlanar}_{\mathcal{V}}^{\text{Right}}$ provides a graphical calculus for \mathcal{V} because of the following theorem (due to Joyal and Street): ²¹

²¹Here we have generalized slightly the theorem provided by Joyal and Street in [JS88], however the proof is nearly identical. Their theorem applies to *rigid* strict monoidal categories. Also they require that $V = (V^*)^{\vee} = (V^{\vee})^*$ rather than the natural canonical isomorphism in lemma (2.42). They prove that the *value* (not defined here) of a fully colored (k, l) -polarised planar graph is invariant under *polarised isotopies*. We also mention that their proof applies only to piecewise linear graphs.

Theorem 2.53 (Joyal, Street). *Let \mathcal{V} be a **right-rigid** strict monoidal category. Consider the right-rigid strict monoidal category $\text{PolarPlanar}_{\mathcal{V}}^{\text{Right}}$. Denote by $|_V$ a vertical line segment colored by an object $V \in \text{Ob}(\mathcal{V})$. Denote by \cup_V and \cap_V the elementary pieces depicted on the left in figure (7). Then there is a unique monoidal functor*

$$F : \text{PolarPlanar}_{\mathcal{V}}^{\text{Right}} \rightarrow \mathcal{V} \quad (2.54)$$

such that

$$F([V]) = V \quad (2.55)$$

$$F(|_V) = id_V$$

$$F(\boxed{f}) = f$$

$$F(\cup_V) = b_V$$

$$F(\cap_V) = d_V$$

$$(2.56)$$

From now on we may use the graphical calculus when proving theorems about right-rigid strict monoidal categories without further explicit mention of $\text{PolarPlanar}_{\mathcal{V}}^{\text{Right}}$ and the functor F . Also in our graphical proofs we will occasionally drop the \bullet that marks minima and maxima.

Example 2.57. $\text{PolarPlanar}_{\mathcal{V}}^{\text{Left}}$: Let \mathcal{V} be a left-rigid strict monoidal category. Then in a similar fashion we can define a left-rigid strict monoidal category $\text{PolarPlanar}_{\mathcal{V}}^{\text{Left}}$. To start we note that a **left (k, l) -polarised planar graph** is the same as a right (k, l) -polarised planar graph (without change), however for notational clarity we use \blacksquare instead of \bullet . Furthermore a **left-polarised isotopy** is the same as a right-polarised isotopy.

The changes appear when we define a **fully colored left (k, l) -polarised planar graph**. In this case we are only allowed to color line segments attached to maxima/minima \blacksquare as on the *right side* of figure (7). Furthermore we can always switch between a maximum and an appropriate coupon $\boxed{\delta}$ (and likewise for a minimum and a coupon $\boxed{\beta}$).

The graphical calculus follows from a similar theorem:

Theorem 2.58 (Joyal, Street). *Let \mathcal{V} be a **left-rigid** strict monoidal category. Consider the left-rigid strict monoidal category $\text{PolarPlanar}_{\mathcal{V}}^{\text{Left}}$. Denote by $|_V$ a vertical line segment colored by an object $V \in \text{Ob}(\mathcal{V})$. Denote by*

\vee_V and \wedge_V the elementary pieces depicted on the right in figure (7). Then there is a unique monoidal functor

$$F : \text{PolarPlanar}_{\mathcal{V}}^{\text{Left}} \rightarrow \mathcal{V} \quad (2.59)$$

such that

$$\begin{aligned} F([[V]]) &= V & (2.60) \\ F(|_V) &= id_V \\ F(\boxed{f}) &= f \\ F(\vee_V) &= \beta_V \\ F(\wedge_V) &= \delta_V \end{aligned}$$

Example 2.61. PolarPlanar $_{\mathcal{V}}$: Finally we may consider a category with both left and right rigidity. Let \mathcal{V} be a rigid strict monoidal category. Then we may combine the structures in $\text{PolarPlanar}_{\mathcal{V}}^{\text{Right}}$ and $\text{PolarPlanar}_{\mathcal{V}}^{\text{Left}}$ to form a rigid strict monoidal category $\text{PolarPlanar}_{\mathcal{V}}$. Now we are allowed to use both \bullet and \blacksquare and the moves depicted in *both* figures (4) and (5) (we now simply call the relevant isotopies **polarised isotopies**).

The graphical calculus is encoded in this theorem:

Theorem 2.62 (Joyal, Street). *Let \mathcal{V} be a **rigid** strict monoidal category. Consider the rigid strict monoidal category $\text{PolarPlanar}_{\mathcal{V}}$. Denote by $|_V$ a vertical line segment colored by an object $V \in \text{Ob}(\mathcal{V})$. Denote by \cup_V , \cap_V , \vee_V , and \wedge_V the elementary pieces depicted in figure (7). Then there is a unique monoidal functor*

$$F : \text{PolarPlanar}_{\mathcal{V}} \rightarrow \mathcal{V} \quad (2.63)$$

such that

$$\begin{aligned} F([[V]]) &= V & (2.64) \\ F(|_V) &= id_V \\ F(\boxed{f}) &= f \\ F(\cup_V) &= b_V \\ F(\cap_V) &= d_V \\ F(\vee_V) &= \beta_V \\ F(\wedge_V) &= \delta_V \end{aligned}$$

Remark 2.65. To make contact with the original theorem proven by Joyal and Street, we mention that in the present context a \bullet cannot create/annihilate with a \blacksquare (as we may be tempted to do in figure (8) for example).

However, if we have a category (a “strict” version) such that $V = (V^*)^\vee = (V^\vee)^*$ and the isomorphisms p_V and q_V in lemma (2.42) are *equal* to id_V then a \bullet can create/annihilate with a \blacksquare . This is the situation originally studied in [JS88].

Technical lemmas

The following lemma is due to Kelly and Laplaza [KL80] originally formulated in the context of pivotal categories (see below). We prove it to demonstrate the graphical calculus: ²²

Lemma 2.66 (Kelly, Laplaza). *Let \mathcal{V} be a right-rigid strict monoidal category. Then $\text{Hom}(V \otimes U, W) \simeq \text{Hom}(V, W \otimes U^*)$ and $\text{Hom}(V, U \otimes W) \simeq \text{Hom}(U^* \otimes V, W)$.*

Proof. We prove only the first isomorphism, leaving the second to the reader. Let $f \in \text{Hom}(V \otimes U, W)$. A graphical presentation for f is given in figure (14(a)). We define a morphism $\bar{f} \in \text{Hom}(V, W \otimes U^*)$ in figure (14(b)).

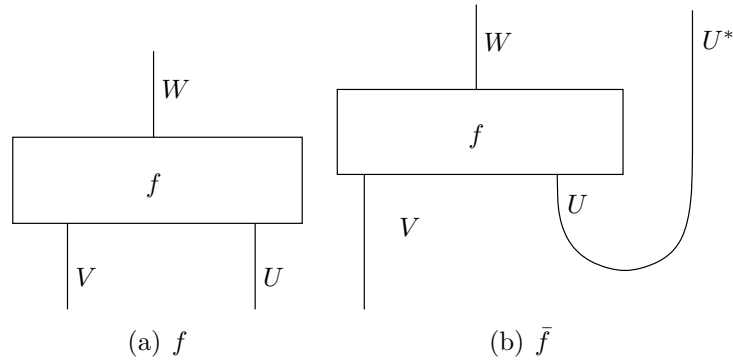

Figure 14: Graphical presentation of f and \bar{f}

Likewise, for a morphism $g \in \text{Hom}(V, W \otimes U^*)$ we define a morphism $\tilde{g} \in \text{Hom}(V \otimes U, W)$ as in the right side of figure (15).

²²The \bullet symbols have been omitted.

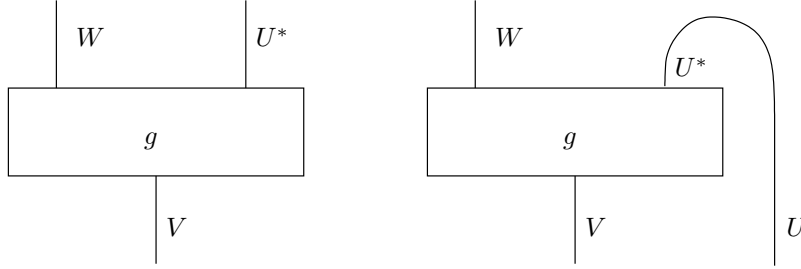

Figure 15: Graphical presentation of g and \tilde{g}

In order to show the isomorphism of Hom spaces we merely need to verify that $\tilde{f} = f$ and $\tilde{g} = g$. We show only the first equality in figure (16) (using right rigidity) and leave the second to the reader. \square

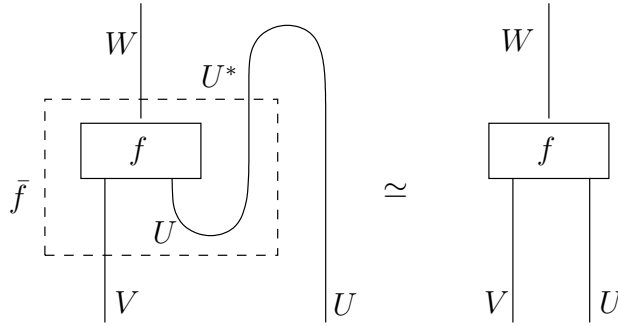

Figure 16: Proof that $\tilde{f} = f$ using right rigidity

Corollary 2.67. *Let \mathcal{V} be a right-rigid strict monoidal category. Then $\text{Hom}(U, W) \simeq \text{Hom}(\mathbb{1}, W \otimes U^*) \simeq \text{Hom}(W^* \otimes U, \mathbb{1})$.*

There is also a similar lemma and corollary for left-rigid strict monoidal categories:

$$\text{Hom}(V, W \otimes U) \simeq \text{Hom}(V \otimes U^\vee, W) \quad (2.68)$$

$$\text{Hom}(U \otimes V, W) \simeq \text{Hom}(V, U^\vee \otimes W) \quad (2.69)$$

Pivotal categories

We mentioned above that for right-rigid strict monoidal categories there are *not* (in general) canonical isomorphisms $V \xrightarrow{\sim} V^{**}$. We can consider cate-

gories that have this structure. Consider a family of distinguished natural isomorphisms (one for each object V)

$$\text{piv}_V : V \xrightarrow{\sim} V^{**} \quad (2.70)$$

We say that the category is **pseudo-pivotal** if the natural isomorphisms respect the monoidal structure:

$$\text{piv}_{V \otimes W} = \text{piv}_V \otimes \text{piv}_W \quad (2.71)$$

$$\text{piv}_{\mathbb{1}} = \text{id}_{\mathbb{1}} \quad (2.72)$$

The first equality uses the unique isomorphism $(V \otimes W)^{**} \cong V^{**} \otimes W^{**}$ and the second uses the unique isomorphism $\mathbb{1} \cong \mathbb{1}^{**}$ (both of which come from the right-rigidity structure alone as in proposition (2.29)).

Remark 2.73. More carefully, let us give notation to the unique isomorphisms guaranteed by the right-rigid version of proposition (2.29) (compare to what is done in remark (2.45)). We denote them

$$\phi_{V \otimes W} : W^* \otimes V^* \xrightarrow{\sim} (V \otimes W)^* \quad (2.74)$$

$$(\phi_{V \otimes W})^* : (V \otimes W)^{**} \xrightarrow{\sim} (W^* \otimes V^*)^*$$

$$\phi_{W^* \otimes V^*} : V^{**} \otimes W^{**} \xrightarrow{\sim} (W^* \otimes V^*)^*$$

Since

$$\text{piv}_{V \otimes W} : V \otimes W \xrightarrow{\sim} (V \otimes W)^{**} \quad (2.75)$$

$$\text{piv}_V \otimes \text{piv}_W : V \otimes W \xrightarrow{\sim} V^{**} \otimes W^{**}$$

We see that the statement

$$\text{piv}_{V \otimes W} = \text{piv}_V \otimes \text{piv}_W \quad (2.76)$$

is abusive shorthand for the correct condition

$$\text{piv}_{V \otimes W} = ((\phi_{V \otimes W}^*)^{-1} \circ \phi_{W^* \otimes V^*}) \circ (\text{piv}_V \otimes \text{piv}_W) \quad (2.77)$$

Similar remarks hold for $\text{piv}_{\mathbb{1}}$. We leave them to the reader to formulate.

As usual there is a left-rigid version of the following proposition:

Proposition 2.78. *Let \mathcal{V} be a pseudo-pivotal right-rigid strict monoidal category. Then \mathcal{V} is also left rigid. Furthermore there exists a canonical choice of left rigidity.*

Proof. For a *pseudo-pivotal* category \mathcal{V} the functor $(\)^* : \mathcal{V}^{\text{op}} \rightarrow \mathcal{V}$ defines an equivalence of categories. This is easy to see since any object $V \cong V^{**}$ is isomorphic to the dual of some object (namely V^*), so $(\)^*$ is *essentially surjective* (compare with the proof of lemma (2.49)).

By lemma (2.49) this shows that \mathcal{V} is also left-rigid. There is a canonical choice given by

$$\begin{aligned} V^\vee &:= V^* & (2.79) \\ \beta_V &:= (\text{id}_{V^*} \otimes \text{piv}_V^{-1}) \circ b_{V^*} \\ \delta_V &:= d_{V^*} \circ (\text{piv}_V \otimes \text{id}_{V^*}) \end{aligned}$$

□

Remark 2.80. We shall see below that if we start with *braiding* instead of pseudo-pivotal then a similar result holds (i.e. braiding defines a canonical left rigidity on a right-rigid category). Also a *dagger* structure (see below) defines a canonical left rigidity on a right-rigid category. We shall study how the various left-rigidity structures interact (they are not the *same*, but by proposition (2.29) they are related by unique isomorphisms). For example see fact (2.122).

Definition 2.81. A pseudo-pivotal right-rigid strict monoidal category is called **pivotal** if the following diagram commutes:

$$\begin{array}{ccc} V^* & \xrightarrow{\text{piv}_{V^*}} & V^{***} \\ & \searrow \text{id}_{V^*} & \downarrow (\text{piv}_V)^* \\ & & V^* \end{array} \quad (2.82)$$

The next proposition shows how the pivotal condition is relevant. It demonstrates that for a pivotal category the isomorphisms piv_V and $p_V : V \xrightarrow{\sim} (V^*)^\vee$ described in lemma (2.42) are the same.

Proposition 2.83. *Let \mathcal{V} be a pseudo-pivotal right-rigid strict monoidal category equipped with the canonical left rigidity*

$$\begin{aligned} V^\vee &:= V^* & (2.84) \\ \beta_V &:= (\text{id}_{V^*} \otimes \text{piv}_V^{-1}) \circ b_{V^*} \\ \delta_V &:= d_{V^*} \circ (\text{piv}_V \otimes \text{id}_{V^*}) \end{aligned}$$

Then consider the canonical natural isomorphisms $p_V : V \xrightarrow{\sim} (V^*)^\vee = V^{**}$ and $q_V : V \xrightarrow{\sim} (V^\vee)^* = V^{**}$ in lemma (2.42). We have $q_V = \text{piv}_V$ automatically. However $p_V = \text{piv}_V$ if and only if \mathcal{V} is pivotal.

Proof. An exercise in the graphical calculus, and left to the reader. \square

Definition 2.85. A pivotal right-rigid strict monoidal category (shortened to “pivotal category”) is called *strict* when for each object V we have an identification $V = V^{**}$ and the pivotal isomorphism is just the identity $\text{piv}_V = \text{id}_V$.

In light of the following proposition (proven in [JS91b] Chapter 3) we can restrict our attention to *strict* pivotal categories:

Proposition 2.86 (Joyal, Street). *Every pivotal category is monoidally equivalent to a strict one.*

Quantum trace for pseudo-pivotal categories

Remark 2.87. If we are given a family of morphisms $\text{piv}_V : V \rightarrow V^{**}$ (pseudo-pivotal or not) then we can define the **right quantum trace** $\text{tr}_q^R(f)$ of any morphism $f : V \rightarrow V$ as a scalar (see above)

$$\mathbb{1} \xrightarrow{b_V} V \otimes V^* \xrightarrow{f \otimes \text{id}_{V^*}} V \otimes V^* \xrightarrow{\text{piv}_V \otimes \text{id}_{V^*}} V^{**} \otimes V^* \xrightarrow{d_{V^*}} \mathbb{1} \quad (2.88)$$

The corresponding diagram in $\text{PolarPlanar}_{\mathcal{V}}^{\text{Right}}$ is illuminating and the reader is encouraged to draw it (see figure (17) for example).

We note that if the category is pseudo-pivotal then given morphisms $f : V \rightarrow V$ and $g : W \rightarrow W$ we have

$$\text{tr}_q^R(f \otimes g) = \text{tr}_q^R(f) \bullet \text{tr}_q^R(g) \quad (2.89)$$

where the RHS is scalar multiplication. A proof is outlined in figure (17).

In addition, for a pseudo-pivotal category the quantum trace is cyclic, i.e. given $f : V \rightarrow W$ and $g : W \rightarrow V$ we have

$$\text{tr}_q^R(f \circ g) = \text{tr}_q^R(g \circ f) \quad (2.90)$$

The proof is a simple graphical exercise. The first step is to use *naturality* of the family of pseudo-pivotal isomorphisms

$$g^{**} \circ \text{piv}_W = \text{piv}_V \circ g \quad (2.91)$$

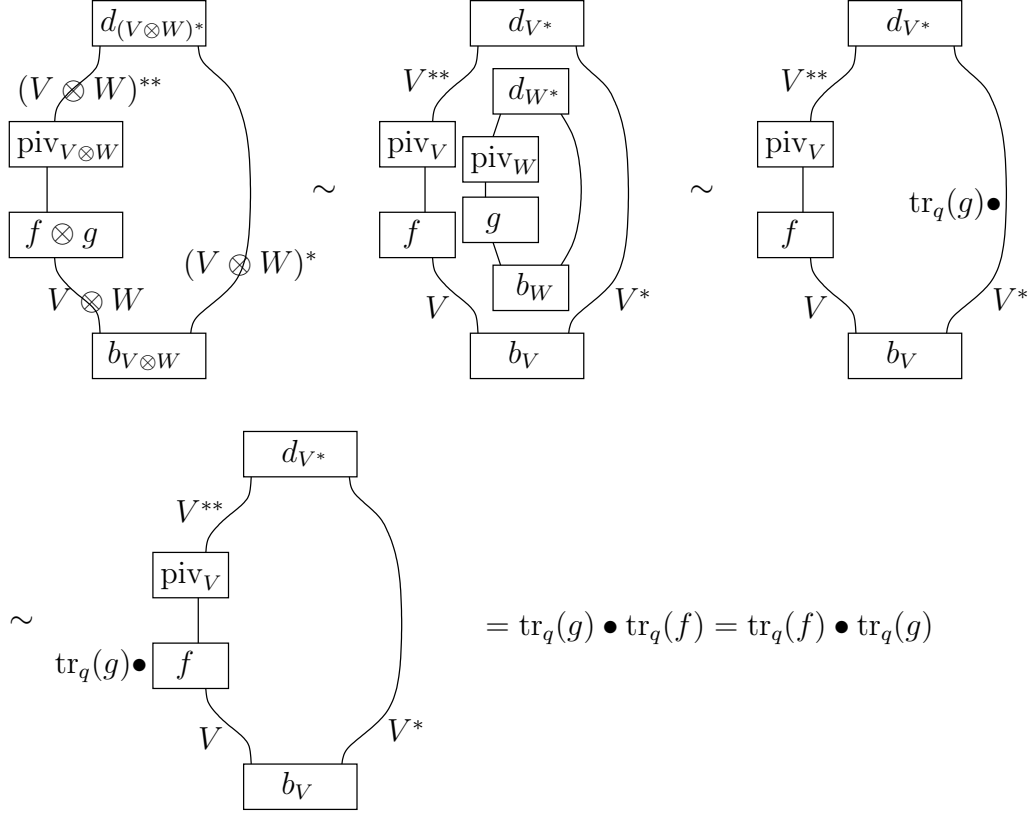

Figure 17: For pseudo-pivotal categories we prove $\text{tr}_q(f \otimes g) = \text{tr}_q(f) \bullet \text{tr}_q(g)$ (note this is the *right* quantum trace, however we drop the R superscript). From the first diagram to the second we have used $\text{piv}_{V \otimes W} = \text{piv}_V \otimes \text{piv}_W$ (the ϕ isomorphisms are abusively omitted). From the third to the fourth diagram we have used $f \otimes (\text{tr}_q(g) \bullet \text{id}_{V^*}) = \text{tr}_q(g) \bullet (f \otimes \text{id}_{V^*})$ which follows from the last property in equation (2.13).

to move g above piv_V . The next steps simply use the definition of the transpose $g^{**} = (g^*)^* = ((g)^*)^*$ in terms of birth and death morphisms.

The right quantum trace defines a notion of **right quantum dimension** $\dim_q^R(V)$ of any object V . The definition is simply

$$\dim_q^R(V) := \text{tr}_q^R(\text{id}_V) \tag{2.92}$$

The reader may guess that there is also a canonical notion of **left quantum trace** defined for pseudo-pivotal categories. It is defined as follows:

given an endomorphism $f : V \rightarrow V$ we consider its transpose $f^* : V^* \rightarrow V^*$. Then the left quantum trace is defined as

$$\mathrm{tr}_q^L(f) := \mathrm{tr}_q^R(f^*) \tag{2.93}$$

It is an easy exercise to check that tr_q^L satisfies the same cyclic and multiplicative properties that tr_q^R does.

A pivotal category is called **spherical** if $\mathrm{tr}_q^R = \mathrm{tr}_q^L$, i.e. if $\mathrm{tr}_q^R(f) = \mathrm{tr}_q^R(f^*)$ for every morphism f .

Quantum Information from Rigidity

Abramsky and Coecke [AC08] proposed the following *coarse* definition for a quantum mechanical system: ²³

1. *Preparation* of an entangled state is a *name*.
2. An *observational branch* (measurement) is a *coname*.

They argue that for a compact closed category this encodes (at a primitive level) the notions of entanglement and quantum information flow. The justification is given as a set of core lemmas (see below) that mimic the fundamental properties of quantum information flow in known examples. We shall study these aspects further for braided systems in forthcoming work.

Using the framework already described we can easily generalize this to right-rigid strict monoidal categories. Identical “core lemmas” follow from the graphical calculus (using F and the category $\mathrm{PolarPlanar}_V^{\mathrm{Right}}$):

Theorem 2.94. *let \mathcal{V} be a right-rigid strict monoidal category. Then we have the Abramsky-Coecke “quantum information flow” notions of **absorption** (figure (18)), **compositionality** (figure (19)), **compositional CUT** (figure (20)), and **backward absorption** (figure (21)).*

In light of this generalization it is natural to consider categorical quantum mechanics for braided systems.

²³Compare to the usual interpretation of the birth and death morphisms as particle/antiparticle pair creation and annihilation, respectively.

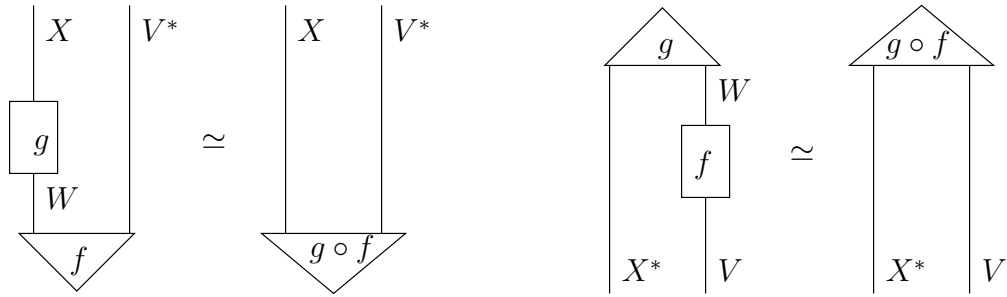

Figure 18: Absorption for $f : V \rightarrow W$ and $g : W \rightarrow X$

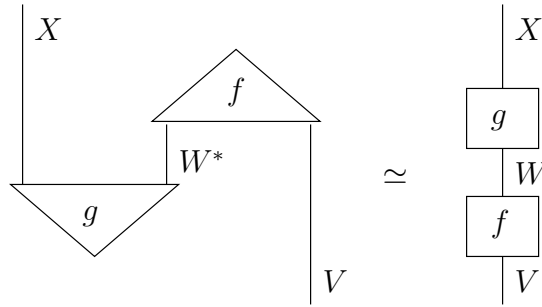

Figure 19: Compositionality for $f : V \rightarrow W$ and $g : W \rightarrow X$

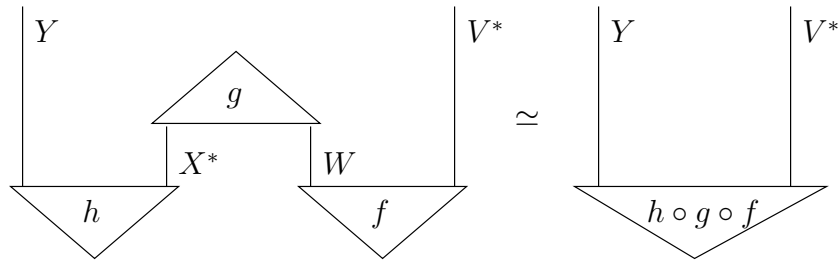

Figure 20: Compositional CUT for $f : V \rightarrow W$, $g : W \rightarrow X$, and $h : X \rightarrow Y$

Braided strict monoidal categories

We return to strict monoidal categories (temporarily dropping the rigidity conditions). We will add rigidity momentarily.

Definition 2.95. A **braided strict monoidal category** is a strict monoidal category equipped with a family of natural *braiding* isomorphisms (for all

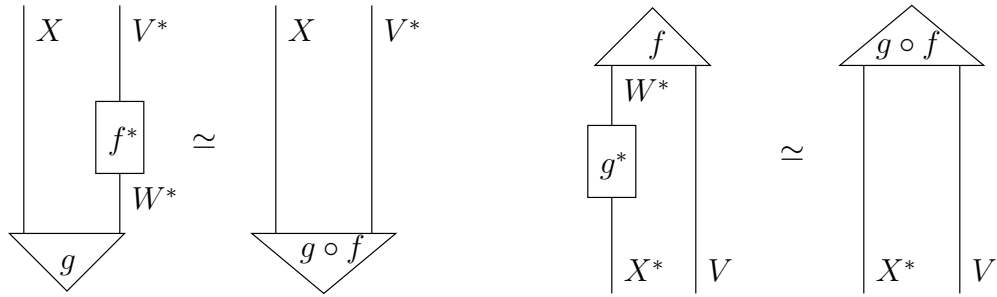

Figure 21: Backward absorption for $f : V \rightarrow W$ and $g : W \rightarrow X$

pairs of objects)

$$\{c_{U,V} : U \otimes V \rightarrow V \otimes U\} \quad (2.96)$$

The braiding isomorphisms represent a *weak* form of commutativity. Note that it is *not* usually true that $c_{V,U} \circ c_{U,V} = \text{id}_{U \otimes V}$. If this condition is satisfied then the category is called **symmetric** (we are interested in non-symmetric categories here).

The braiding isomorphisms are required to satisfy the *hexagon relations* described in equations (2.97) and (2.98):

$$\begin{array}{ccc}
 A \otimes (B \otimes C) & \xrightarrow{c_{A,B \otimes C}} & (B \otimes C) \otimes A \\
 \text{id} \swarrow & & \searrow \text{id} \\
 (A \otimes B) \otimes C & & B \otimes (C \otimes A) \\
 c_{A,B} \otimes \text{id}_C \searrow & & \swarrow \text{id}_{B \otimes C} \\
 (B \otimes A) \otimes C & \xrightarrow{\text{id}} & B \otimes (A \otimes C)
 \end{array} \quad (2.97)$$

$$\begin{array}{ccc}
& (U \otimes V) \otimes W \xrightarrow{c_{U \otimes V, W}} W \otimes (U \otimes V) & \\
& \swarrow \text{id} & \nwarrow \text{id} \\
U \otimes (V \otimes W) & & (W \otimes U) \otimes V \\
& \searrow \text{id}_{U \otimes c_{V, W}} & \nearrow c_{U, W} \otimes \text{id}_V \\
& U \otimes (W \otimes V) \xrightarrow{\text{id}} (U \otimes W) \otimes V &
\end{array} \tag{2.98}$$

Joyal and Street constructed in [JS91a] and [JS93] a graphical calculus for braided strict monoidal categories that is analogous to $\text{ProgPlanar}_{\mathcal{V}}$. In this case the graphs are not planar, but instead are *progressive graphs in 3 dimensions* up to **3D progressive isotopies**.²⁴ We now review the construction, leaving many details to the references.

Example 2.99. $\text{Prog3D}_{\mathcal{V}}$: Let \mathcal{V} be a braided strict monoidal category. Before we define the graphical calculus category $\text{Prog3D}_{\mathcal{V}}$ we require a definition.

Definition 2.100. A (k, l) -**3D progressive graph between levels a and b** is a compact Hausdorff space embedded in $\mathbb{R}^2 \times [a, b] \subset \mathbb{R}^3$. It is constructed from the following elementary pieces (see e.g. figure (22)):

1. “Vertical” *smooth line segments*
2. *Coupons* (rectangular horizontal strips)

Here we must be more careful with what is meant by “vertical” line segment (thinking of the z -axis as the vertical axis). For a smooth line segment to be “vertical” the projection onto the interval $[a, b]$ must be a smooth embedding (i.e. the line segment is never horizontal at any point).

We also must be more careful with the definition of *coupon*. A coupon is a flat 2D strip that must always be parallel with the xz -plane (we always draw pictures from the *front projection* perspective, i.e. the projection onto the xz -plane with the positive y axis pointing *into* the picture. We always ensure to remember over/undercrossings in the projection). The coupons must always

²⁴Informally “progressive” means that the smooth line segments must never become horizontal.

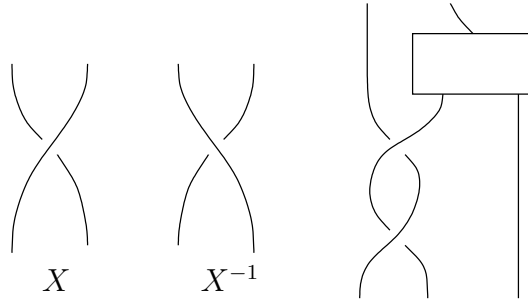

Figure 22: Some examples of 3D progressive graphs

remain rectangular. The top and bottom of any coupon must always remain parallel with the top and bottom of the ambient space $\mathbb{R}^2 \times [a, b]$.

As with the other graphical calculi the elementary pieces are not allowed to intersect except at finitely-many points: line segments are allowed to terminate at isolated points on the “in” (bottom) or “out” (top) sides of coupons. They are also allowed to terminate at k isolated points (**inputs**) on the bottom $\mathbb{R}^2 \times \{a\}$ or at l isolated points (**outputs**) on the top $\mathbb{R}^2 \times \{b\}$. Line segments cannot terminate elsewhere. Furthermore coupons cannot intersect the top $\mathbb{R}^2 \times \{b\}$ or bottom $\mathbb{R}^2 \times \{a\}$.

We only want to consider (k, l) -3D progressive graphs up to **3D progressive isotopies**. These are smooth 3D isotopies of $\mathbb{R}^2 \times [a, b] \subset \mathbb{R}^3$ subject to the following constraints:

1. Line segments must always remain “vertical”.
2. Coupons must always remain coupons (see restrictions above - especially note that from the front projection perspective coupons must always remain “facing up”).
3. The ordering of inputs (and outputs) must remain fixed (relative to the front projection).

We define a **fully colored (k, l) -3D progressive graph between levels a and b** in the obvious way (as with the other graphical calculi) using the braided strict monoidal category \mathcal{V} .

The definition of the category itself (which we denote $\text{Prog3D}_{\mathcal{V}}$) is defined analogously to the category $\text{ProgPlanar}_{\mathcal{V}}$ - hence we do not write it here (we

emphasize that all morphisms, i.e. fully colored (k, l) -3D progressive graphs, are defined only up to 3D progressive isotopies). It is left as an exercise to show that $\text{Prog3D}_{\mathcal{V}}$ is a braided strict monoidal category. The justification for the terminology “graphical calculus” is given by the following theorem:

Theorem 2.101 (Joyal, Street). *Let \mathcal{V} be a braided **strict** monoidal category. Consider the braided **strict** monoidal category $\text{Prog3D}_{\mathcal{V}}$. Denote by $|_V$ a vertical line segment colored by an object $V \in \text{Ob}(\mathcal{V})$, \boxed{f} a coupon colored with an appropriate morphism f in \mathcal{V} , and $X_{U,V}$ the 3d progressive graph depicted on the left side of figure (22) where the strands are colored by U and V on the bottom, respectively. Then there is a unique monoidal functor*

$$F : \text{Prog3D}_{\mathcal{V}} \rightarrow \mathcal{V} \tag{2.102}$$

such that

$$\begin{aligned} F(|_V) &= V \\ F(|_V) &= id_V \\ F(\boxed{f}) &= f \\ F(X_{U,V}) &= c_{U,V} \end{aligned} \tag{2.103}$$

Braided rigid strict monoidal categories

In this subsection we consider strict monoidal categories that are both braided and rigid. We can combine aspects of $\text{Prog3D}_{\mathcal{V}}$ and $\text{PolarPlanar}_{\mathcal{V}}$ to produce an extended graphical calculus (which we still denote $\text{Prog3D}_{\mathcal{V}}$).

To start since \mathcal{V} is braided we can still use the graphical calculus $\text{Prog3D}_{\mathcal{V}}$ provided in the previous subsection for braided strict monoidal categories without alteration.

Without more comment the birth/death morphisms have no special meaning in $\text{Prog3D}_{\mathcal{V}}$ (they are merely coupons). However it is clear that if we obtain a rectangular piece of the diagram that is *planar* (i.e. no over/undercrossings from the front-projection perspective) then we can utilize on that rectangle the rigidity graphical calculus provided by $\text{PolarPlanar}_{\mathcal{V}}^{\text{Right}}$, $\text{PolarPlanar}_{\mathcal{V}}^{\text{Left}}$, or $\text{PolarPlanar}_{\mathcal{V}}$ (whichever is appropriate).

To avoid making incorrect isotopies (recall all isotopies must remain 3D progressive) we avoid the \bullet and \blacksquare notations used above in the rigidity sections

and use explicitly the coupon notation (e.g. $\boxed{b_V}$, $\boxed{d_V}$, $\boxed{\beta_V}$, and $\boxed{\delta_V}$). Thus the coupons explicitly remain “face up” from the front-projection perspective.

For practical purposes this combination of braided and rigid graphical calculi suffices.

Definition 2.104. A **braided right-rigid strict monoidal category** is a strict monoidal category that is both braided and right-rigid.

A similar definition holds for braided left-rigid strict monoidal categories and also for braided rigid strict monoidal categories.

To illustrate the limitations of the graphical calculus we provide an example of a “bad” move in figure (23) (this would for example indicate that $V = V^{**}$). The problem is that the isotopy is not 3D progressive.

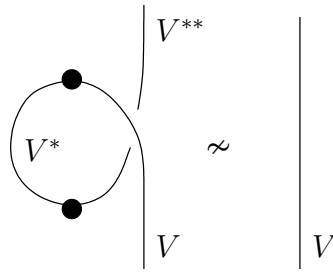

Figure 23: An incorrect isotopy in $\text{Prog3D}_{\mathcal{V}}$

Braiding and rigidity interact intimately when both exist. For example, we have the following proposition due to Joyal and Street ([JS93] Proposition 7.2) which we prove to illustrate the graphical calculus provided by $\text{Prog3D}_{\mathcal{V}}$:

Proposition 2.105 (Joyal, Street). *Let \mathcal{V} be a **braided** right-rigid strict monoidal category. Then \mathcal{V} is equipped with a canonical left rigidity structure (hence \mathcal{V} is rigid).*

Proof. Let V be an object in \mathcal{V} . Define the left dual to be equal to the right dual, i.e. $V^\vee = V^*$. Define the left rigidity by the following birth and death

²⁵Obviously a similar left rigidity proposition is true.

morphisms:

$$\beta_V : \mathbb{1} \rightarrow V^\vee \otimes V \tag{2.106}$$

$$\mathbb{1} \xrightarrow{b_V} V \otimes V^* = V \otimes V^\vee \xrightarrow{c_{V^\vee, V}^{-1}} V^\vee \otimes V$$

$$\delta_V : V \otimes V^\vee \rightarrow \mathbb{1}$$

$$V \otimes V^\vee \xrightarrow{c_{V, V^\vee}} V^\vee \otimes V = V^* \otimes V \xrightarrow{d_V} \mathbb{1}$$

In Prog3D_V the picture is as in figure (24)

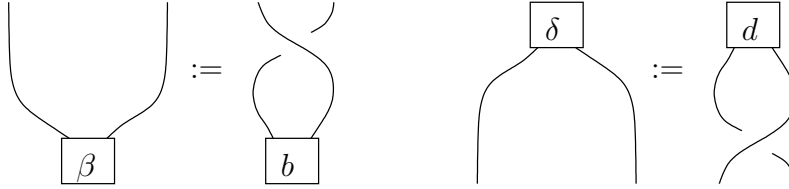

Figure 24: Braiding defines a left rigidity structure on a right-rigid strict monoidal category.

It remains to verify the conditions in equation (2.28). We verify only one of them, leaving the other to the reader. Consider the morphism as depicted on the left side of figure (25). We want to show that this is id_V .

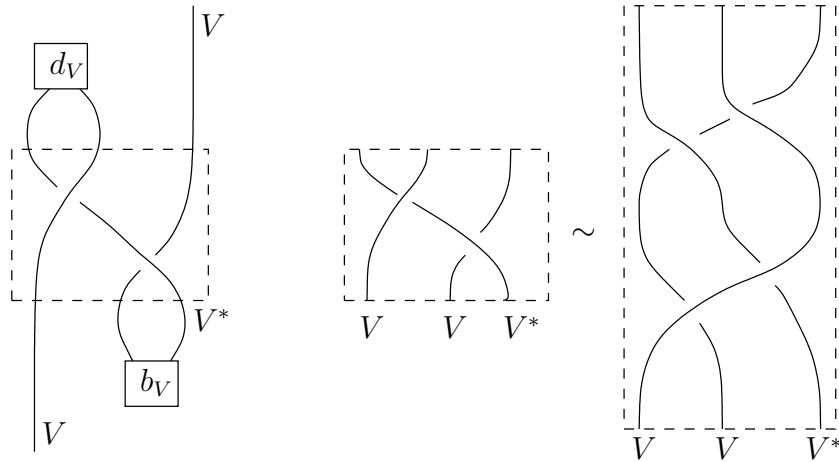

Figure 25: Verifying one of the left rigidity conditions.

The dashed rectangular area depicted on the left side of figure (25) is just the morphism

$$V \otimes V \otimes V^* \xrightarrow{\text{id}_V \otimes c_{V^*,V}^{-1}} V \otimes V^* \otimes V \xrightarrow{c_{V,V^*} \otimes \text{id}_V} V^* \otimes V \otimes V \quad (2.107)$$

However it is easy to see from the (progressive 3D) isotopy depicted on the right side of figure (25) that this morphism is the same as

$$V \otimes V \otimes V^* \xrightarrow{c_{V,V \otimes V^*}} V \otimes V^* \otimes V \xrightarrow{c_{V^* \otimes V, V}^{-1}} V^* \otimes V \otimes V \quad (2.108)$$

Hence the entire morphism depicted on the left side of figure (25) can be written

$$V \xrightarrow{\text{id}_V \otimes b_V} V \otimes V \otimes V^* \xrightarrow{c_{V,V \otimes V^*}} V \otimes V^* \otimes V \xrightarrow{c_{V^* \otimes V, V}^{-1}} V^* \otimes V \otimes V \xrightarrow{d_V \otimes \text{id}_V} V \quad (2.109)$$

By naturality of the braiding c we can pass the birth and death morphisms b_V and d_V through resulting in the morphism

$$V = V \otimes \mathbb{1} \xrightarrow{c_{V,\mathbb{1}}} \mathbb{1} \otimes V \xrightarrow{b_V \otimes \text{id}_V} V \otimes V^* \otimes V \xrightarrow{\text{id}_V \otimes d_V} V \otimes \mathbb{1} \xrightarrow{c_{\mathbb{1},V}^{-1}} \mathbb{1} \otimes V = V \quad (2.110)$$

Using the right-rigidity conditions in equation (2.25) the two morphisms in the center annihilate, and it is also an easily-proven fact (c.f. Chapter XIII in [Kas95]) that $c_{V,\mathbb{1}}$ and $c_{\mathbb{1},V}^{-1}$ are just the identity id_V . Hence the whole morphism is just id_V . \square

In light of the canonical left rigidity constructed in the previous proposition and the fact that different left rigidity structures are related by unique isomorphisms (as in proposition (2.29)) we might ask concretely how V^\vee and V^* are related in an arbitrary braided *rigid* strict monoidal category (i.e. in a category with a separate left rigidity structure V^\vee and the canonical left rigidity denoted $V^{\vee'} := V^*$ constructed in the previous proposition).

Corollary 2.111. *Let \mathcal{V} be a braided rigid strict monoidal category. Let V be an object in \mathcal{V} . Denote by $V^{\vee'} := V^*$ the canonical left rigidity described in proposition (2.105). Then the **unique** natural isomorphism $V^{\vee'} := V^* \cong V^\vee$ that respects left rigidity in the sense of proposition (2.29) is depicted in figure (26).*

Proof. Consider the morphisms $V^* \rightarrow V^\vee$ and $V^\vee \rightarrow V^*$ constructed on the left and right sides of figure (26). It is left as an exercise to show that these can be stacked in either order and (3D progressively) isotoped to id_{V^*} and id_{V^\vee} , respectively. Hence they are canonical *isomorphisms*. We note that the proof requires manipulations in both Prog3D_γ and $\text{PolarPlanar}_\gamma$ separately.

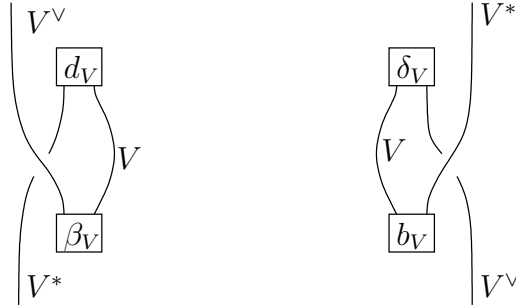

Figure 26: Canonical natural isomorphisms between V^* and V^\vee .

Naturality can also be proven graphically and is left to the reader. Let $f : V \rightarrow W$ be a morphism. Then it must be shown that the following diagram commutes:

$$\begin{array}{ccc} V^{\vee\vee} & \xrightarrow{\sim} & V^\vee \\ f^{\vee\vee} \uparrow & & \uparrow f^\vee \\ W^{\vee\vee} & \xrightarrow{\sim} & W^\vee \end{array} \quad (2.112)$$

It is an interesting exercise to prove (using the β'_V and δ'_V defined by the previous proposition) that this naturality condition is equivalent to the following commutative diagram:

$$\begin{array}{ccc} V^* & \xrightarrow{\sim} & V^\vee \\ f^* \uparrow & & \uparrow f^\vee \\ W^* & \xrightarrow{\sim} & W^\vee \end{array} \quad (2.113)$$

Finally to prove that these isomorphisms uniquely respect left rigidity it remains to prove that the isomorphisms depicted in figure (26) satisfy the commutative diagrams in proposition (2.29). Again this is an exercise in the graphical calculus and is left to the reader.

We note that there is a different family of canonical natural isomorphisms depicted in figure (27). However, they do not respect left rigidity in the sense of proposition (2.29). \square

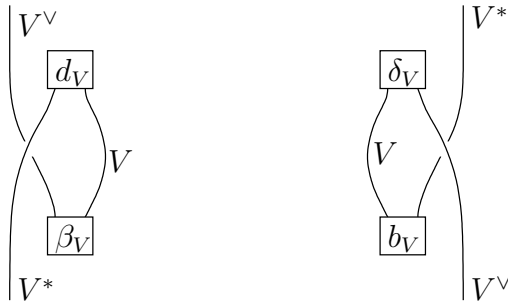

Figure 27: Canonical natural isomorphisms between V^* and V^\vee that do not respect left rigidity.

Remark 2.114. In light of these facts we can restrict our attention to braided rigid strict monoidal categories without loss of generality. However, we must be careful to keep track of different left rigidity structures and the corresponding families of unique isomorphisms φ in proposition (2.29). Otherwise we may be led to false conclusions.

Remark 2.115. We remarked already that in a right-rigid strict monoidal category we do not necessarily have a family of canonical isomorphisms $V \xrightarrow{\sim} V^{**}$ (and a similar statement for left-rigid categories). However, if the category is *braided* then we do have such canonical (*and natural*) isomorphisms defined by figure (28).²⁶

Copying notation from [BK00] Section 2.2 we denote these isomorphisms ψ_V (one for each object V). We emphasize that we *do not have* $\psi_{V \otimes W} \stackrel{?}{=} \psi_V \otimes \psi_W$ (otherwise every braided right-rigid strict monoidal category would be *pseudo-pivotal* - see the balancing structure below to determine how far they “miss”).

It is an exercise in the graphical calculus to construct an inverse to show that these morphisms are *isomorphisms*. It is also a graphical exercise to show that these isomorphisms are *natural*.

Quantum trace for braided rigid categories

Remark 2.116. From the isomorphisms $\psi_V : V^{**} \xrightarrow{\sim} V$ defined in figure (28) combined with the construction in remark (2.87) we can define the notions

²⁶Because we shall use this family of canonical natural isomorphisms later for other purposes we define them backward $\psi_V : V^{**} \xrightarrow{\sim} V$.

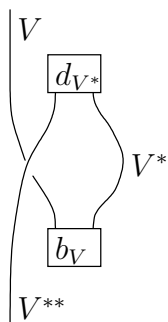

Figure 28: Isomorphism ψ_V .

of **left/right quantum trace** for braided rigid strict monoidal categories. It is an amusing exercise in the graphical calculus to show that $\text{tr}_q^L = \text{tr}_q^R$.

However, we shall view this quantum trace as incomplete and not particularly useful (in fact we shall modify these definitions below). For example, despite the equality $\text{tr}_q^L = \text{tr}_q^R$ we *cannot* conclude that any braided rigid category is spherical because it may not even be pivotal. In fact ψ_V does not even define a *pseudo-pivotal* structure.

As a symptom of this it is easy to show that we *do not have* $\text{tr}_q(f \otimes g) = \text{tr}_q(f) \bullet \text{tr}_q(g)$. On the other hand, an illuminating graphical exercise verifies that this quantum trace *is* cyclic.

Balanced Categories

We now add a categorical notion of “twists”.²⁷ We disregard rigidity for now since it is not necessary for the following definition:

Definition 2.117. A **balanced braided strict monoidal category** (often shortened to “balanced category”)²⁸ is a braided strict monoidal category equipped with a family of natural isomorphisms (twists) for all objects:

$$\{\theta_U : U \rightarrow U\} \tag{2.118}$$

We may be tempted to enforce monoidal compatibility $\theta_{V \otimes W} = \theta_V \otimes \theta_W$, however this is not what we want here. Instead we require that the following

²⁷Modelled after twisting a ribbon/belt.

²⁸We note that the term “balanced” in other literature often assumes rigidity and imposes an additional axiom (e.g. [BK00]). We follow the more loose traditional definition and reserve the extra axiom for ribbon categories (see below).

balancing diagram commutes:

$$\begin{array}{ccc}
 U \otimes V & \xrightarrow{\theta_{U \otimes V}} & U \otimes V \\
 \theta_U \otimes \theta_V \downarrow & & \uparrow c_{V,U} \\
 U \otimes V & \xrightarrow{c_{U,V}} & V \otimes U
 \end{array} \tag{2.119}$$

This can be written as a formula for convenience:

$$\theta_{U \otimes V} = c_{V,U} \circ c_{U,V} \circ (\theta_U \otimes \theta_V) \tag{2.120}$$

It can be easily shown that $\theta_{\mathbb{1}} = \text{id}_{\mathbb{1}}$.

Remark 2.121. As it has been constructed $\text{Prog3D}_{\mathcal{V}}$ is not balanced (even if \mathcal{V} is). However $\text{Prog3D}_{\mathcal{V}}$ can be extended easily to be a balanced category if we enforce the move depicted on the right side of figure (29).

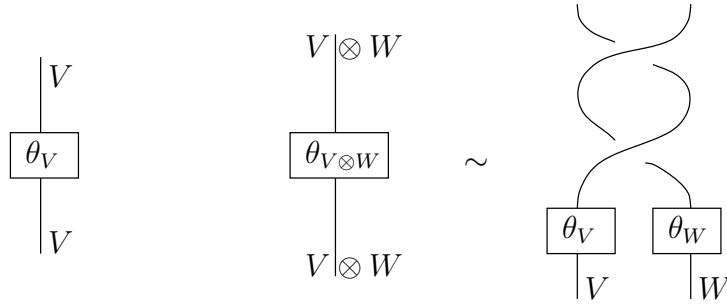

Figure 29: Twist isomorphism (left) and the extra move that must be enforced so that $\text{Prog3D}_{\mathcal{V}}$ is balanced whenever \mathcal{V} is.

Balanced rigid strict monoidal categories

In the case of *rigid* braided strict monoidal categories there is an intimate relationship between balanced and pseudo-pivotal:

Fact 2.122. *Let \mathcal{V} be a braided rigid strict monoidal category. Then \mathcal{V} is balanced iff \mathcal{V} is pseudo-pivotal.*

Proof. First suppose that the category is pseudo-pivotal, i.e. we have a natural family of isomorphisms $\text{piv}_V : V \xrightarrow{\sim} V^{**}$ such that

$$\begin{aligned}\text{piv}_{V \otimes W} &= \text{piv}_V \otimes \text{piv}_W \\ \text{piv}_{\mathbb{1}} &= \text{id}_{\mathbb{1}}\end{aligned}\tag{2.123}$$

Define the twist $\theta_V := \psi_V \circ \text{piv}_V$ where ψ_V is defined in figure (28). Then it is an exercise in $\text{Prog3D}_{\mathcal{V}}$ to verify the balancing condition in equation (2.120).

We must be careful here since it is *not* true (as is sometimes claimed) that $\psi_{V \otimes W} = c_{W,V} \circ c_{V,W} \circ (\psi_V \otimes \psi_W)$ because the unique isomorphisms $(V \otimes W)^{**} \cong W^{**} \otimes V^{**}$ in the right-rigid version of proposition (2.29) must be taken into account (compare with remark (2.45)).

The remedy is that the pseudo-pivotal condition $\text{piv}_{V \otimes W} = \text{piv}_V \otimes \text{piv}_W$ is also abusive - we should instead use equation (2.77) which accounts for these same isomorphisms. Putting these together the reader can verify that in the expression for $\theta_{V \otimes W} := \psi_{V \otimes W} \circ \text{piv}_{V \otimes W}$ the obstructing isomorphisms exactly cancel each other.

Conversely suppose \mathcal{V} is balanced with natural twist isomorphisms θ_V . Define $\text{piv}_V := \psi_V^{-1} \circ \theta_V$. The pseudo-pivotal conditions are easily verified algebraically (again we actually must obtain the expression in equation (2.77) instead of the abusive expression $\text{piv}_{V \otimes W} = \text{piv}_V \otimes \text{piv}_W$). \square

We note that the trick described in lemma (4.3) is often useful for manipulating balanced right-rigid strict monoidal categories.

Partial Trace

We noted in remark (2.87) that for a pseudo-pivotal right-rigid strict monoidal category there are canonical notions of right *and* left quantum traces, i.e. for a morphism $f : V \rightarrow V$ we obtain a scalars $\text{tr}_q^R(f)$ and $\text{tr}_q^L(f)$.

Furthermore we noted two properties that both tr_q^R and tr_q^L satisfy (we drop the superscripts since these statements apply to both the left and right traces):

- For $f : V \rightarrow V$ and $g : W \rightarrow W$ we have

$$\text{tr}_q(f \otimes g) = \text{tr}_q(f) \bullet \text{tr}_q(g)\tag{2.124}$$

- Cyclicity, i.e. for $f : V \rightarrow W$ and $g : W \rightarrow V$ we have

$$\text{tr}_q(f \circ g) = \text{tr}_q(g \circ f)\tag{2.125}$$

Now let \mathcal{V} be a *balanced* right-rigid strict monoidal category. According to fact (2.122) this category is pseudo-pivotal. Then the induced right quantum trace defined by remark (2.87) using $\text{piv}_V := \psi_V^{-1} \circ \theta_V$ is (in the language of braids and twists) depicted on the LHS of figure (30).

We also can similarly define the induced left quantum trace. It is a graphical exercise to prove that the left quantum trace is equivalent to the diagram on the RHS of figure (30).

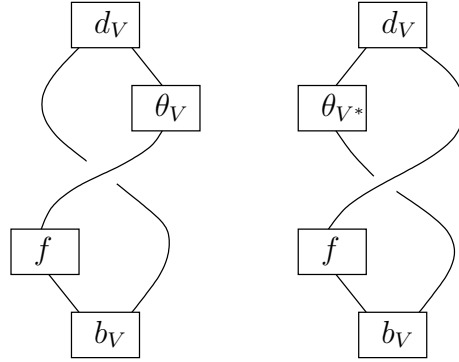

Figure 30: $\text{tr}_q^R(f)$ and $\text{tr}_q^L(f)$ defined for balanced right-rigid strict monoidal categories. For ribbon categories (see below) these are equivalent.

We can now remark further on the incomplete “quantum trace” defined in remark (2.116) for any braided right-rigid strict monoidal category (the left and right traces were equivalent there by coincidence). We stated (and left the proof to the reader) that this trace is *cyclic*, but does not satisfy $\text{tr}_q(f \otimes g) = \text{tr}_q(f) \bullet \text{tr}_q(g)$.²⁹ We now see that the missing ingredient for the quantum trace defined in remark (2.116) is a compatible twist structure.³⁰

As pointed out in [AC08] a generalized notion of **partial trace** for balanced categories was studied in detail by Joyal, Street, and Verity in [JSV96]. Partial traces appear often in quantum information theory, hence we include them where necessary.

Definition 2.126. Let \mathcal{V} be a balanced monoidal category (not necessarily rigid). Let A , B , and V be objects in \mathcal{V} . Following [JSV96] we say that \mathcal{V}

²⁹Such a trace is certainly not unique since (for example) we could use an undercrossing rather than an overcrossing.

³⁰and when adding the twist structures as in figure (30) the left and right traces are *not* necessarily equal

is a **traced monoidal category** if it is equipped with a family of functions $\text{tr}_q^{V;A,B} : \text{Hom}(A \otimes V, B \otimes V) \rightarrow \text{Hom}(A, B)$ (one for each triple of objects) subject to various properties (see [JSV96] for a detailed discussion). We say that we are “tracing out” V .

The following fact implies that in most cases of interest we obtain a partial trace “for free” (possibly more than one partial trace).

Fact 2.127. *Let \mathcal{V} be a balanced **right-rigid** strict monoidal category. Then \mathcal{V} is a canonically traced monoidal category (not necessarily uniquely).*

Proof. Consider (for example) figure (31) for a morphism $f : A \otimes V \rightarrow B \otimes V$. It is left to the reader to verify the conditions discussed in [JSV96]. \square

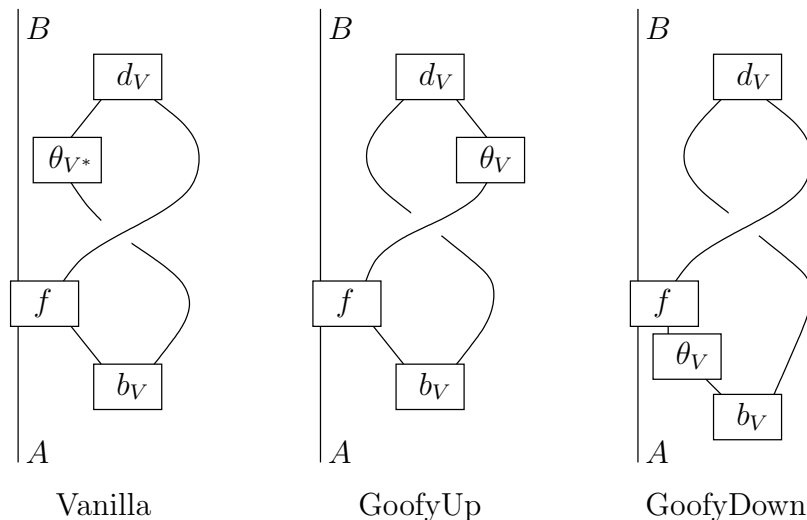

Figure 31: Any balanced right-rigid strict monoidal category comes equipped with a canonical partial trace (here we depict and name three canonical traces). For a ribbon category these are equivalent. We point out fact (4.1) that relates the Goofy partial traces to each other.

Ribbon categories

To clarify a subtlety we first consider the obvious next structure that can be studied: **pivotal rigid braided strict monoidal categories** (note: these are automatically balanced by fact (2.122)). It is sometimes claimed that the

extra pivotal structure in equation (2.82) is equivalent to the extra structure required to define a *ribbon category* (defined below). This is surprisingly false.

In fact we can view *pivotal braided rigid strict monoidal categories* as an intermediate step between balanced rigid strict monoidal categories and ribbon categories. To see this first note that because of proposition (2.86) (due to Joyal and Street) we can restrict our attention to strict pivotal categories.

Strict pivotal categories with braiding structure were studied by Freyd and Yetter in [FY89] (applications can be found in [FY92]). There they developed a graphical calculus (ROTang_S) where “R” means tangles up to *regular* isotopy and “O” means oriented. S is a coloring set. They emphasize that tangles *up to regular isotopy* are not equivalent to *framed* tangles (see figure (32)). In order to define a ribbon category we need the pivotal structure *and* an extra condition (see below) modelled on enforcing figure (32).

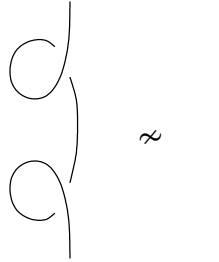

Figure 32: Up to regular isotopy these tangle pieces are *not* the same. However, they are the same up to isotopy of *framed* tangles.

Definition 2.128. A **ribbon category** \mathcal{V} is a balanced right-rigid strict monoidal category subject to one of the following four equivalent *ribbon conditions* (the second and third can be rewritten in many ways):

1. $\theta_{V^*} = (\theta_V)^*$
2. $(\theta_V \otimes \text{id}_{V^*}) \circ b_V = (\text{id}_V \otimes \theta_{V^*}) \circ b_V$
3. $d_V \circ (\theta_{V^*} \otimes \text{id}_V) = d_V \circ (\text{id}_{V^*} \otimes \theta_V)$
4. $(\text{piv}_V)^* \circ \text{piv}_{V^*} = \text{id}_{V^*}$ (i.e. pivotal) **and** $\text{reg2frame}_V = \text{id}_{V^*}$ where reg2frame_V is defined in figure (33)

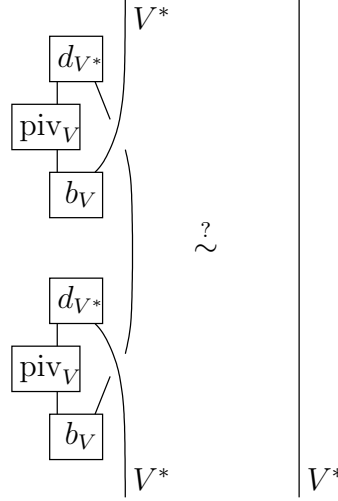

Figure 33: The isomorphism reg2frame_V .

The first 3 conditions are easily shown to be equivalent (using the graphical calculus $\text{Prog3D}_{\mathcal{V}}$ for example). The equivalence of condition (4) is slightly more subtle, hence we provide some details.

We first prove that ribbon condition (1) implies that the category is pivotal. Since $\theta_V = \psi_V \circ \text{piv}_V$ we have

$$\begin{aligned}\theta_{V^*} &= \psi_{V^*} \circ \text{piv}_{V^*} \\ (\theta_V)^* &= (\text{piv}_V)^* \circ (\psi_V)^*\end{aligned}\tag{2.129}$$

Hence

$$(\text{piv}_V)^* \circ \text{piv}_{V^*} = (\theta_V)^* \circ ((\psi_V)^*)^{-1} \circ (\psi_{V^*})^{-1} \circ \theta_{V^*}\tag{2.130}$$

We study the central expression $((\psi_V)^*)^{-1} \circ (\psi_{V^*})^{-1}$ graphically in figure (34) (the right-most diagram is obtained from the move in figure (29)). The right-most diagram in figure (34) corresponds to the algebraic expression

$$(\text{id}_{V^*} \otimes d_{V^*}) \circ (\text{id}_{V^*} \otimes \theta_{V^{**} \otimes V^*}) \circ (\text{id}_{V^*} \otimes \theta_{V^{**}}^{-1} \otimes \theta_{V^*}^{-1}) \circ (b_{V^*} \otimes \text{id}_{V^*})\tag{2.131}$$

By naturality of θ we have that $d_{V^*} \circ \theta_{V^{**} \otimes V^*} = \theta_{\mathbb{1}} \circ d_{V^*} = d_{V^*}$. Hence we are left with

$$\begin{aligned}& (\text{id}_{V^*} \otimes d_{V^*}) \circ (\text{id}_{V^*} \otimes \theta_{V^{**}}^{-1} \otimes \theta_{V^*}^{-1}) \circ (b_{V^*} \otimes \text{id}_{V^*}) \\ &= (\text{id}_{V^*} \otimes d_{V^*}) \circ (\text{id}_{V^*} \otimes \theta_{V^{**}}^{-1} \otimes \text{id}_{V^*}) \circ (b_{V^*} \otimes \text{id}_{V^*}) \circ (\text{id}_{\mathbb{1}} \otimes \theta_{V^*}^{-1})\end{aligned}\tag{2.132}$$

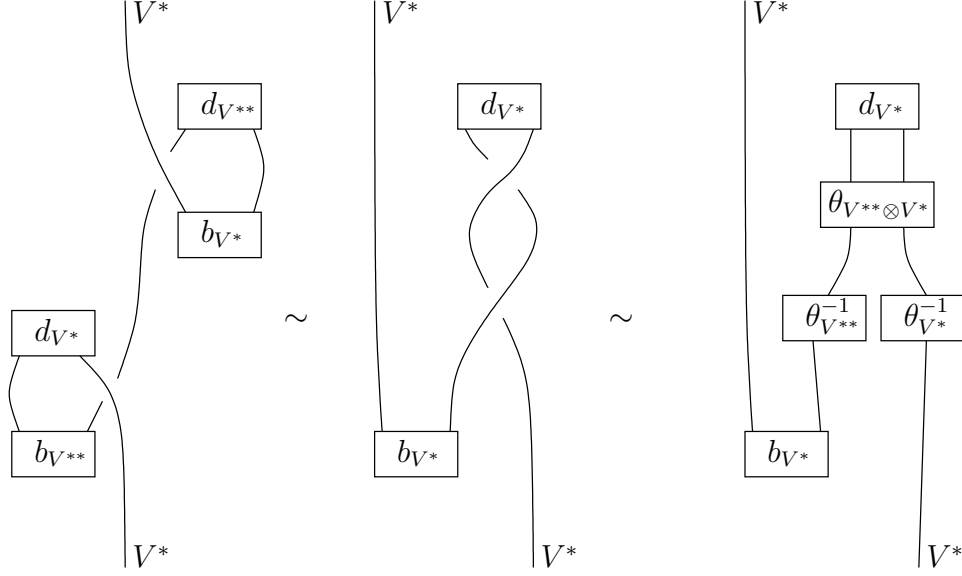

Figure 34: $((\psi_V)^*)^{-1} \circ (\psi_{V^*})^{-1} : V^* \xrightarrow{\sim} V^*$

Using a variant of ribbon condition (2) (which is equivalent to ribbon condition (1)) we can move $\theta_{V^{**}}^{-1}$ to $\theta_{V^*}^{-1}$ giving

$$\begin{aligned}
& (\text{id}_{V^*} \otimes d_{V^*}) \circ (\theta_{V^*}^{-1} \otimes \text{id}_{V^{**}} \otimes \text{id}_{V^*}) \circ (b_{V^*} \otimes \text{id}_{V^*}) \circ (\text{id}_{\mathbb{1}} \otimes \theta_{V^{**}}^{-1}) \quad (2.133) \\
& = (\theta_{V^*}^{-1} \otimes \text{id}_{\mathbb{1}}) \circ (\text{id}_{V^*} \otimes d_{V^*}) \circ (\text{id}_{V^*} \otimes \text{id}_{V^{**}} \otimes \text{id}_{V^*}) \\
& \quad \circ (b_{V^*} \otimes \text{id}_{V^*}) \circ (\text{id}_{\mathbb{1}} \otimes \theta_{V^{**}}^{-1}) \\
& = (\theta_{V^*}^{-1} \otimes \text{id}_{\mathbb{1}}) \circ (\text{id}_{V^*} \otimes d_{V^*}) \circ (b_{V^*} \otimes \text{id}_{V^*}) \circ (\text{id}_{\mathbb{1}} \otimes \theta_{V^{**}}^{-1})
\end{aligned}$$

The birth and death morphisms annihilate (using right-rigidity) leaving us finally with ³¹

$$((\psi_V)^*)^{-1} \circ (\psi_{V^*})^{-1} = (\theta_{V^*}^{-1}) \circ (\theta_{V^*}^{-1}) \quad (2.134)$$

Plugging this into equation (2.130) we get

$$(\text{piv}_V)^* \circ \text{piv}_{V^*} = \text{id}_{V^*} \quad (2.135)$$

Hence any ribbon category is pivotal. We note that the argument is “irreversible” (i.e. pivotal does *not* imply ribbon) since we used the ribbon condition (version (2)) in one of the intermediate steps.

³¹also dispensing with the $\text{id}_{\mathbb{1}}$ factors since we are considering only strict monoidal categories here

To prove $\text{reg2frame}_V = \text{id}_{V^*}$ is straightforward from ribbon condition (1) (armed with the fact that the category is pivotal). The argument is most easily understood by starting with a graphical depiction of the first condition $(\theta_V)^*(\theta_{V^*})^{-1} = \text{id}_{V^*}$ and again using the definition $\theta_V = \psi_V \circ \text{piv}_V$. The pivotal condition must be used once. It is easy to see that all necessary moves are reversible in this case, hence conditions 1 and 4 are equivalent.

Unlike the previous graphical calculi considered the graphical calculus (which we denote Rib_V) for a ribbon category \mathcal{V} is exhaustively documented and we do not reproduce it here. The original references are Freyd and Yetter [FY89] and Reshetikhin and Turaev [RT90], [RT91]. Exhaustive references are Turaev [Tur94] and Bakalov and Kirillov [BK00]. We also refer the reader to [Sti08] for notation and nomenclature consistent with this work.

3 Dagger Categories

We showed in the last section that the quantum information flow paradigm proposed by Abramsky and Coecke can be generalized from compact closed categories to the much weaker structure of right-rigid strict monoidal categories. We have dispensed with the *symmetric* assumption altogether at the cost of introducing more general graphical calculi (in fact we could have considered non-strict monoidal categories since non-strictness encodes spatial proximity).

It is clear that the formalism described thusfar provides only limited predictive (i.e. theorem-proving) power and hence it is not surprising that further structure is required. Following Abramsky and Coecke we assert that the notion of **adjoint** (or “dagger”) plays a fundamental role in the Hilbert space formalism (we distinguish this from the notion of “adjoint” that appears in category theory in the duality structures discussed above).

The most primitive “adjoint” analogue is described by Selinger [Sel07] (such structures appeared in category theory long ago):

Definition 3.1. A **dagger category** \mathcal{V} is a category equipped with a functor $()^\dagger : \mathcal{V} \rightarrow \mathcal{V}^{\text{op}}$ that is the identity on objects. In other words it leaves objects fixed and maps each morphism $f : V \rightarrow W$ to a morphism $f^\dagger : W \rightarrow V$. We require in addition that the functor satisfies:

$$\text{id}_V^\dagger = \text{id}_V \quad (g \circ f)^\dagger = f^\dagger \circ g^\dagger \quad f^{\dagger\dagger} = f \quad (3.2)$$

Definition 3.3. In a dagger category we say that an isomorphism $f : V \rightarrow W$ is **unitary** if $f^\dagger = f^{-1}$. A morphism $f : V \rightarrow V$ is called **self-adjoint** if $f^\dagger = f$.

To begin we consider *monoidal* categories that have a dagger structure. Again we restrict ourselves to strict categories: ³²

Definition 3.4. A **dagger strict monoidal category** is a strict monoidal category equipped with a dagger structure subject to monoidal compatibility:

$$(f \otimes g)^\dagger = f^\dagger \otimes g^\dagger \quad (3.5)$$

Dagger rigid strict monoidal categories

Abramsky and Coecke confine their attention to dagger *symmetric* monoidal categories, i.e. dagger monoidal categories equipped with a symmetric braiding (often denoted σ) such that σ is unitary. In fact they further restrict their attention to *strongly compact closed categories*. These are dagger symmetric *left-rigid* monoidal categories. The rigidity and symmetry are required to be compatible by enforcing the following commutative diagram:

$$\begin{array}{ccc} \mathbb{1} & \xrightarrow{\beta_V} & V^\vee \otimes V \\ & \searrow \delta_V^\dagger & \downarrow \sigma_{V^\vee, V} \\ & & V \otimes V^\vee \end{array} \quad (3.6)$$

Our goal is to study more general categories, hence we dispense with the symmetric structure altogether (and thus also the last commuting diagram).

Definition 3.7. A **dagger right-rigid strict monoidal category** is a dagger strict monoidal category that is equipped with a right rigidity structure.

We could temporarily define our setting for quantum mechanics to be *dagger right-rigid strict monoidal categories*, however consider the following proposition ³³

³²For non-strict monoidal categories Abramsky and Coecke restrict themselves to the case where the associativity, left unit, and right unit isomorphisms are unitary.

³³Compare to proposition (2.105) for the case of braided right-rigid strict monoidal categories.

Proposition 3.8. *Let \mathcal{V} be a **dagger** right-rigid strict monoidal category. Then \mathcal{V} is equipped with a canonical left rigidity structure (hence \mathcal{V} is rigid).*

Proof. Let V be an object in \mathcal{V} . Define $V^\vee := V^*$. Setting $\beta_V := (d_V)^\dagger$ and $\delta_V := (b_V)^\dagger$ (and using the dagger axioms) it is straightforward to verify that equation (2.28) is satisfied. \square

If we combine this with the uniqueness of rigidity described in proposition (2.29) then we see that we lose no generality by confining our attention to **dagger rigid strict monoidal categories** where the right and left rigidity are related as in proposition (3.8). We enforce this as a definition:

Definition 3.9. A **dagger rigid strict monoidal category** is a dagger strict monoidal category equipped with right and left rigidity where $V^\vee = V^*$, $\beta_V = (d_V)^\dagger$, and $\delta_V = (b_V)^\dagger$.

Remark 3.10. We reserve our study of *braided* dagger structures for the material below since the correct definitions are more subtle than one might expect. The graphical calculus is useful to build intuition (although we emphasize that it is not necessary).

Graphical dagger action

We assert that the pictorial action of $()^\dagger$ mirrors a graph top to bottom as in figure (35).³⁴ Line segments retain their coloring, whereas coupons \boxed{f} are replaced with coupons colored by daggered morphisms $\boxed{f^\dagger}$.

In 3 dimensions (i.e. braided systems) we will encounter two separate extensions of the symmetric case (and hence two types of graphical daggering).

Theorem 3.11. *Let \mathcal{V} be a dagger strict monoidal category. Then the strict monoidal category $\text{ProgPlanar}_{\mathcal{V}}$ obtains a compatible dagger structure by mirroring top to bottom and replacing \boxed{f} with $\boxed{f^\dagger}$ as in figure (35).*

Furthermore the unique monoidal functor $F : \text{ProgPlanar}_{\mathcal{V}} \rightarrow \mathcal{V}$ respects the dagger, i.e. $F(\Gamma^{\text{mirror}}) = (F(\Gamma))^\dagger$ for a morphism Γ in $\text{ProgPlanar}_{\mathcal{V}}$.

³⁴This graphical dagger action has probably been studied for certain types of categories, however we are unaware of references. We hope to study it here in some generality.

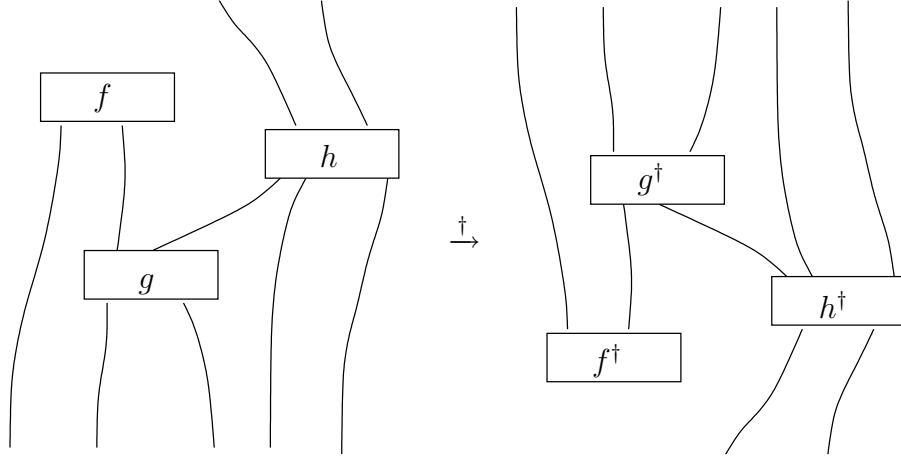

Figure 35: $()^\dagger$ mirrors graphs top to bottom

Proof. We sketch the proof. It is obvious that the mirroring procedure satisfies the three conditions in equation (3.2). For compatibility with the monoidal structure we need to check that mirroring satisfies equation (3.5). However this is also obvious because \otimes in ProgPlanar_γ places graphs Γ and Γ' adjacent to each other. Hence clearly under mirroring we have

$$(\Gamma \otimes \Gamma')^\dagger = \Gamma^\dagger \otimes \Gamma'^\dagger \quad (3.12)$$

We conclude that ProgPlanar_γ is a dagger strict monoidal category.

To prove that the functor F from theorem (2.20) respects the dagger structure we note that since mirroring respects equations (3.2) and (3.5) in ProgPlanar_γ (and since F is a monoidal functor) it suffices to check the statement on the elementary pieces. We have

$$\begin{aligned} (\text{id}_V)^\dagger &= \text{id}_V = F(|_V) = F(|_V^{\text{mirror}}) \\ F(\boxed{f}^{\text{mirror}}) &= F(\boxed{f^\dagger}) = f^\dagger \end{aligned} \quad (3.13)$$

(see theorem (2.20) for notation). □

Graphical dagger rigid strict monoidal categories

We consider the graphical dagger action for dagger rigid strict monoidal categories (recall definition (3.9)).

Theorem 3.14. *Let \mathcal{V} be a dagger rigid strict monoidal category. Then the rigid strict monoidal category $\text{PolarPlanar}_{\mathcal{V}}$ obtains a compatible dagger structure by mirroring top to bottom and replacing \boxed{f} with $\boxed{f^\dagger}$ as in figure (35).*

Furthermore the unique monoidal functor $F : \text{PolarPlanar}_{\mathcal{V}} \rightarrow \mathcal{V}$ respects the dagger, i.e. $F(\Gamma^{\text{mirror}}) = (F(\Gamma))^\dagger$ for a morphism Γ in $\text{PolarPlanar}_{\mathcal{V}}$.

Proof. We first must check that the dagger is compatible with the strict monoidal structure. The argument is identical to that in theorem (3.11).

The category $\text{PolarPlanar}_{\mathcal{V}}$ is already a rigid strict monoidal category. Since in \mathcal{V} we have $V^\vee = V^*$ we also have in $\text{PolarPlanar}_{\mathcal{V}}$ equality of objects $[[V]]^\vee := [[V^\vee]] = [[V^*]] =: [[V]]^*$.

Finally the conditions in \mathcal{V} that relate left and right rigidity (i.e. $\beta_V = (d_V)^\dagger$ and $\delta_V = (b_V)^\dagger$) are both necessary and sufficient to make the dagger (mirroring) compatible with the rigidity structure in $\text{PolarPlanar}_{\mathcal{V}}$. In the notation of theorem (2.62) this means that $\vee_V = (\cap_V)^{\text{mirror}}$ and $\wedge_V = (\cup_V)^{\text{mirror}}$ (the “sufficient” argument is trivial; for the “necessary” argument we must appeal to uniqueness of both left and right rigidity as in proposition (2.29)).

Finally, the argument that F respects the dagger structure is almost identical to that in theorem (3.11). We only need to check the statement on the extra elementary pieces:

$$\begin{aligned} F((\cap_V)^{\text{mirror}}) &= F(\vee_V) = \beta_V = (d_V)^\dagger \\ F((\cup_V)^{\text{mirror}}) &= F(\wedge_V) = \delta_V = (b_V)^\dagger \\ F((\vee_V)^{\text{mirror}}) &= F(\cap_V) = d_V = (\beta_V)^\dagger \\ F((\wedge_V)^{\text{mirror}}) &= F(\cup_V) = b_V = (\delta_V)^\dagger \end{aligned} \tag{3.15}$$

□

Dagger braided strict monoidal categories

Now we wish to consider the graphical dagger action for braided categories. Unfortunately we have not yet defined the notion of “dagger braided strict monoidal category”. In the symmetric case considered by Abramsky and Coecke they required that the family of symmetry isomorphisms be unitary, i.e. $\sigma^\dagger = \sigma^{-1}$.

The natural extension would be to require the braiding isomorphisms to be unitary. However unitarity puts strong restrictions on the categories when

rigidity is included (see below), and hence we also consider an alternative definition with much weaker restrictions. Both definitions reduce to that of Abramsky and Coecke in the symmetric case.

Definition 3.16. A **Type I dagger braided strict monoidal category** is a dagger strict monoidal category that is also braided. The braiding and dagger structure must be compatible via the following **unitary** condition on the family of natural braiding isomorphisms $c_{V,W} : V \otimes W \rightarrow W \otimes V$:

$$(c_{V,W})^\dagger = (c_{V,W})^{-1} \quad \text{unitary} \quad (3.17)$$

This definition corresponds to the “mirror” graphical dagger action already described (using the *front projection* in $\text{Prog3D}_{\mathcal{V}}$) in the sense of the next proposition.

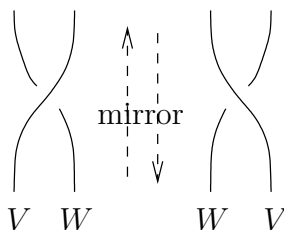

Figure 36: Type I graphical action of $(\)^\dagger$ (mirroring the front projection in $\text{Prog3D}_{\mathcal{V}}$) maps $X_{V,W}$ to $(X_{V,W})^{\text{mirror}} = (X_{V,W})^{-1}$. This implies strong restrictions when rigidity is included.

Theorem 3.18. *Let \mathcal{V} be a Type I dagger braided strict monoidal category (as in definition (3.16)). Then the braided strict monoidal category $\text{Prog3D}_{\mathcal{V}}$ obtains a Type I compatible dagger structure by (from the front-projection perspective) mirroring top to bottom and replacing each colored coupon \boxed{f} with the colored coupon $\boxed{f^\dagger}$.*

Furthermore the unique monoidal functor $F : \text{Prog3D}_{\mathcal{V}} \rightarrow \mathcal{V}$ respects the dagger, i.e. $F(\Gamma^{\text{mirror}}) = (F(\Gamma))^\dagger$ for a morphism Γ in $\text{Prog3D}_{\mathcal{V}}$.

Proof. We first must check that the dagger is compatible with the strict monoidal structure. The argument is identical to that in theorem (3.11).

The category $\text{Prog3D}_{\mathcal{V}}$ is a braided strict monoidal category. It is trivial to check in figure (36) that the braiding $X_{V,W}$ (in the notation of theorem (2.101)) satisfies $(X_{V,W})^{\text{mirror}} = X_{V,W}^{-1}$.

Finally, the argument that F respects the dagger structure is almost identical to that in theorem (3.11). We only need to check the statement on the extra elementary piece:

$$F((X_{V,W})^{\text{mirror}}) = F(X_{V,W}^{-1}) = c_{V,W}^{-1} = (c_{V,W})^\dagger \quad (3.19)$$

□

Since we will encounter strong restrictions using definition (3.16) when we add rigidity (see lemma (3.29)) we can explore the following alternative definitions (however unitarity is not imposed):

Definition 3.20. A **Type II dagger braided strict monoidal category** is a dagger strict monoidal category that is also braided. The braiding and dagger structure must be compatible via the following **non-unitary** condition on the family of natural braiding isomorphisms $c_{V,W} : V \otimes W \rightarrow W \otimes V$:

$$(c_{V,W})^\dagger = c_{W,V} \quad \text{non-unitary} \quad (3.21)$$

Since in the symmetric case $c_{W,V} = c_{V,W}^{-1}$ this definition also reduces to that of Abramsky and Coecke.

Definition 3.22. Type II graphical dagger action in 3d: The corresponding Type II pictorial action of $()^\dagger$ in 3 dimensions is a two-step process (which we also sometimes denote $()^{\text{IImirror}}$):

1. First mirror the front projection of the graph top to bottom as in figures (35) and (36). Line segments retain their coloring, whereas coupons \boxed{f} are replaced with coupons colored by daggered morphisms $\boxed{f^\dagger}$.
2. After mirroring replace the resulting graph with a graph where (from the front projection perspective) all overcrossings are changed to undercrossings (and vica versa).

Theorem 3.23. *Let \mathcal{V} be a Type II dagger braided strict monoidal category (as in definition (3.20)). Then the braided strict monoidal category $\text{Prog3D}_{\mathcal{V}}$ obtains a Type II compatible dagger structure by using the Type II 3d graphical dagger action described in definition (3.22).*

Furthermore the unique monoidal functor $F : \text{Prog3D}_{\mathcal{V}} \rightarrow \mathcal{V}$ respects the dagger, i.e. $F(\Gamma^{\text{IImirror}}) = (F(\Gamma))^\dagger$ for a morphism Γ in $\text{Prog3D}_{\mathcal{V}}$.

Proof. The proof is almost identical to that in theorem (3.18).

The category $\text{Prog3D}_{\mathcal{Y}}$ is a braided strict monoidal category. It is trivial to check (by drawing pictures) that the braiding $X_{V,W}$ (in the notation of theorem (2.101)) satisfies $(X_{V,W})^{\text{Imirror}} = X_{W,V}$.

Finally, the argument that F respects the dagger structure only requires that we check the statement on the extra elementary piece:

$$F((X_{V,W})^{\text{Imirror}}) = F(X_{W,V}) = c_{W,V} = (c_{V,W})^\dagger \quad (3.24)$$

□

Dagger braided rigid strict monoidal categories

Let us add *rigidity* to both Types I and II dagger braided strict monoidal categories. **From now on we leave it to the reader to formulate the graphical dagger action correspondences (as in theorems (3.18) and (3.23)).**

We already argued in proposition (2.105) that any braided right-rigid strict monoidal category is also left-rigid (with $V^\vee = V^*$ and left rigidity defined in figure (24): $\beta_V = c_{V^\vee, V}^{-1} \circ b_V$ and $\delta_V = d_V \circ c_{V, V^\vee}$). On the other hand we already have from definition (3.9) that for a dagger rigid strict monoidal category $V^\vee = V^*$, $\beta'_V = (d_V)^\dagger$ and $\delta'_V = (b_V)^\dagger$.

Although both structures were constructed from the same right-rigidity (and although $V^\vee = V^*$ are the same *objects*) we cannot assume that the resulting left-rigidity *morphisms* (β and δ) are the same - hence we decorated one with primes and the other without. By proposition (2.29) they are related by a natural family of *unique* isomorphisms $\varphi_V : V^\vee \xrightarrow{\sim} V^\vee$.

In light of these considerations we add rigidity to Type I dagger braided strict monoidal categories (definition (3.16)) in the following manner:

Definition 3.25. A **Type I dagger braided rigid strict monoidal category** is a dagger strict monoidal category equipped with rigidity and braiding. The rigidity must satisfy ³⁵

$$V^\vee = V^* \quad \beta'_V = (d_V)^\dagger \quad \delta'_V = (b_V)^\dagger \quad (3.26)$$

³⁵We keep the $()'$ decoration to agree with the notation of proposition (2.29) and the notation in the previous paragraphs. We drop it in later use.

The family of natural braiding isomorphisms must satisfy **unitarity**:

$$(c_{V,W})^\dagger = c_{V,W}^{-1} \quad \text{unitary} \quad (3.27)$$

Finally we require that the braiding and rigidity must be compatible up to a natural family of unique isomorphisms φ_V . This is equivalent to forcing the following diagrams to commute:

$$\begin{array}{ccc} \mathbb{1} & \xrightarrow{\beta'_V} & V^\vee \otimes V & & V \otimes V^\vee & \xrightarrow{\delta'_V} & \mathbb{1} & (3.28) \\ b_V \downarrow & & \uparrow \varphi_V^{-1} \otimes \text{id}_V & & \downarrow \text{id}_V \otimes \varphi_V & & \uparrow d_V \\ V \otimes V^\vee & \xrightarrow{(c_{V^\vee,V})^{-1}} & V^\vee \otimes V & & V \otimes V^\vee & \xrightarrow{c_{V,V^\vee}} & V^\vee \otimes V \end{array}$$

Compare with equation (3.6). These diagrams are required to be compatible with *each other* as well, hence we must be careful to always check that the restrictions described in the following lemma are satisfied (which can be thought of as conditions on φ_V).

We have the following *Type I restriction lemma*:

Lemma 3.29. *Let \mathcal{V} be a Type I dagger braided rigid strict monoidal category as in definition (3.25). Then we have the following restrictions:*

$$\begin{aligned} d_V \circ (\varphi_V^\dagger \otimes \text{id}_V) \circ c_{V^\vee,V}^{-1} &= d_V \circ (\varphi_V \otimes \text{id}_V) \circ c_{V,V^\vee} & (3.30) \\ c_{V^\vee,V}^{-1} \circ (\text{id}_V \otimes \varphi_V^{-1}) \circ b_V &= c_{V,V^\vee} \circ (\text{id}_V \otimes \varphi_V^{\dagger-1}) \circ b_V \end{aligned}$$

Proof. We derive the first restriction by solving for $(b_V)^\dagger$ in two different ways. The second can be derived similarly by solving for $(d_V)^\dagger$ in two different ways.

We have (recalling $V^\vee = V^*$):

$$d_V = (\beta'_V)^\dagger \quad (3.31)$$

$$\begin{aligned} &= ((\varphi_V^{-1} \otimes \text{id}_V) \circ c_{V^\vee,V}^{-1} \circ b_V)^\dagger \\ &= (b_V)^\dagger \circ (c_{V^\vee,V}^{-1})^\dagger \circ (\varphi_V^{-1} \otimes \text{id}_V)^\dagger \\ &= (b_V)^\dagger \circ c_{V^\vee,V} \circ (\varphi_V^{-1\dagger} \otimes \text{id}_V) \end{aligned}$$

$$(3.32)$$

In the first equality we used $\beta'_V = (d_V)^\dagger$ and in the second we used the definition in equation (3.28). In the final equality we used unitarity of c . Solving for $(b_V)^\dagger$ we obtain

$$(b_V)^\dagger = d_V \circ (\varphi_V^\dagger \otimes \text{id}_V) \circ c_{V^\vee, V}^{-1} \quad (3.33)$$

On the other hand we have

$$(b_V)^\dagger = \delta'_V = d_V \circ (\varphi_V \otimes \text{id}_V) \circ c_{V, V^\vee} \quad (3.34)$$

In the second equality we used the definition in equation (3.28) and naturality of c .

Comparing our two expressions for $(b_V)^\dagger$ we obtain the first restriction. \square

Adding rigidity to Type II dagger braided strict monoidal categories (definition (3.20)) is similar:

Definition 3.35. A **Type II dagger braided rigid strict monoidal category** is a dagger strict monoidal category equipped with rigidity and braiding. The rigidity must satisfy

$$V^\vee = V^* \quad \beta'_V = (d_V)^\dagger \quad \delta'_V = (b_V)^\dagger \quad (3.36)$$

The family of natural braiding isomorphisms must satisfy the **non-unitary** condition:

$$(c_{V, W})^\dagger = c_{W, V} \quad \text{non-unitary} \quad (3.37)$$

Finally we require that the braiding and rigidity must be compatible up to a natural family of unique isomorphisms φ_V . This is equivalent to forcing the following diagrams to commute:

$$\begin{array}{ccc} \mathbb{1} & \xrightarrow{\beta'_V} & V^\vee \otimes V \\ b_V \downarrow & & \uparrow \varphi_V^{-1} \otimes \text{id}_V \\ V \otimes V^\vee & \xrightarrow{(c_{V^\vee, V})^{-1}} & V^\vee \otimes V \end{array} \quad \begin{array}{ccc} V \otimes V^\vee & \xrightarrow{\delta'_V} & \mathbb{1} \\ \downarrow \text{id}_V \otimes \varphi_V & & \uparrow d_V \\ V \otimes V^\vee & \xrightarrow{c_{V, V^\vee}} & V^\vee \otimes V \end{array} \quad (3.38)$$

Again compare with equation (3.6). These diagrams are required to be compatible with *each other* as well, hence we must be careful to always check that the restrictions described in the following lemma are satisfied (which can be thought of as conditions on φ_V).

For Type II the *restriction lemma* is much weaker:

Lemma 3.39. *Let \mathcal{V} be a Type II dagger braided rigid strict monoidal category as in definition (3.35). Then we have the following restrictions:*

$$\begin{aligned} d_V \circ (\varphi_V^\dagger \otimes \text{id}_V) &= d_V \circ (\varphi_V \otimes \text{id}_V) \\ (\text{id}_V \otimes \varphi_V^{-1}) \circ b_V &= (\text{id}_V \otimes \varphi_V^{\dagger-1}) \circ b_V \end{aligned} \quad (3.40)$$

Proof. We derive the first restriction by solving for $(b_V)^\dagger$ in two different ways. The second can be derived similarly by solving for $(d_V)^\dagger$ in two different ways.

We have (recalling $V^\vee = V^*$):

$$\begin{aligned} d_V &= (\beta'_V)^\dagger \\ &= ((\varphi_V^{-1} \otimes \text{id}_V) \circ c_{V^\vee, V}^{-1} \circ b_V)^\dagger \\ &= (b_V)^\dagger \circ (c_{V^\vee, V}^{-1})^\dagger \circ (\varphi_V^{-1} \otimes \text{id}_V)^\dagger \\ &= (b_V)^\dagger \circ c_{V, V^\vee}^{-1} \circ (\varphi_V^{-1\dagger} \otimes \text{id}_V) \end{aligned} \quad (3.41)$$

$$(3.42)$$

In the first equality we used $\beta'_V = (d_V)^\dagger$ and in the second we used the definition in equation (3.28). In the final equality we used the property (non-unitarity) of c . Solving for $(b_V)^\dagger$ we obtain

$$(b_V)^\dagger = d_V \circ (\varphi_V^\dagger \otimes \text{id}_V) \circ c_{V, V^\vee} \quad (3.43)$$

On the other hand we have

$$(b_V)^\dagger = \delta'_V = d_V \circ (\varphi_V \otimes \text{id}_V) \circ c_{V, V^\vee} \quad (3.44)$$

In the second equality we used the definition in equation (3.28) and naturality of c .

Comparing our two expressions for $(b_V)^\dagger$ we obtain the first restriction (we can cancel c on both sides since braidings are isomorphisms). \square

We have noted that (since we have sacrificed unitarity of the braiding c) the Type II restriction lemma (3.39) is much weaker. It is easy to see that the restriction is satisfied if (for example) φ_V is self-adjoint (i.e. $\varphi_V^\dagger = \varphi_V$). In the simplest case we could set $\varphi_V := \text{id}_V$. Then we have the following “strictified” Type II dagger braided rigid strict monoidal category:

Definition 3.45. A **strictified Type II dagger braided rigid strict monoidal category** is a dagger strict monoidal category equipped with rigidity and braiding. The rigidity must satisfy

$$V^\vee = V^* \quad \beta'_V = (d_V)^\dagger \quad \delta'_V = (b_V)^\dagger \quad (3.46)$$

The family of natural braiding isomorphisms must satisfy the **non-unitary** condition:

$$(c_{V,W})^\dagger = c_{W,V} \quad \text{non-unitary} \quad (3.47)$$

Finally we require that the braiding and rigidity must be compatible. This is equivalent to forcing the following diagram to commute (the analogue of the diagram on the RHS of equation (3.38) can be obtained by taking the dagger of this diagram):

$$\begin{array}{ccc} \mathbb{1} & \xrightarrow{\beta'_V} & V^\vee \otimes V \\ & \searrow^{b_V} & \uparrow^{(c_{V^\vee, V})^{-1}} \\ & & V \otimes V^\vee \end{array} \quad (3.48)$$

Again compare with equation (3.6).

Unitary Type II theories

In quantum mechanics we are typically interested in evolution operations that are unitary (to conserve probability). If we impose unitarity on Type II dagger braided rigid strict monoidal categories then we automatically collapse into the symmetric theories already considered by Abramsky and Coecke. The proof of the following “no-go” theorem is straightforward given the previous definitions, lemmas, and propositions:

Theorem 3.49. *Let \mathcal{V} be a Type II dagger braided rigid strict monoidal category (as in definition (3.35)). Suppose that the braiding is unitary, i.e. $c_{V,W}^\dagger = c_{V,W}^{-1}$. Then \mathcal{V} is symmetric.*

Dagger balanced strict monoidal categories

Let us ignore rigidity momentarily and consider instead adding a dagger structure to balanced categories. Since these categories are braided we again have a bifurcation into two types.

Definition 3.50. A **Type I dagger balanced strict monoidal category** is a dagger strict monoidal category that is also balanced. The braiding and dagger structure must be compatible via the following **unitary** condition on the family of natural braiding isomorphisms $c_{V,W} : V \otimes W \rightarrow W \otimes V$:

$$(c_{V,W})^\dagger = (c_{V,W})^{-1} \quad \text{unitary} \quad (3.51)$$

Additionally the family of natural twist isomorphisms $\theta_V : V \xrightarrow{\sim} V$ must also be unitary

$$(\theta_V)^\dagger = (\theta_V)^{-1} \quad \text{unitary} \quad (3.52)$$

Definition 3.53. A **Type II dagger balanced strict monoidal category** is a dagger strict monoidal category that is also balanced. The braiding and dagger structure must be compatible via the following **non-unitary** condition on the family of natural braiding isomorphisms $c_{V,W} : V \otimes W \rightarrow W \otimes V$:

$$(c_{V,W})^\dagger = c_{W,V} \quad \text{non-unitary} \quad (3.54)$$

Additionally the family of natural twist isomorphisms $\theta_V : V \xrightarrow{\sim} V$ must be self-adjoint

$$(\theta_V)^\dagger = \theta_V \quad \text{self-adjoint} \quad (3.55)$$

Dagger balanced rigid strict monoidal categories

We can add *rigidity* to both Types I and II dagger balanced strict monoidal categories.

Definition 3.56. A **Type I dagger balanced rigid strict monoidal category** is a dagger strict monoidal category equipped with rigidity and balancing. The rigidity must satisfy

$$V^\vee = V^* \quad \beta'_V = (d_V)^\dagger \quad \delta'_V = (b_V)^\dagger \quad (3.57)$$

The family of natural braiding isomorphisms must satisfy **unitarity**:

$$(c_{V,W})^\dagger = (c_{V,W})^{-1} \quad \text{unitary} \quad (3.58)$$

The family of natural twist isomorphisms must also satisfy **unitarity**:

$$(\theta_V)^\dagger = (\theta_V)^{-1} \quad \text{unitary} \quad (3.59)$$

Finally we require that the braiding and rigidity must be compatible up to a natural family of unique isomorphisms φ_V . This is equivalent to forcing the following diagrams to commute:

$$\begin{array}{ccc}
\mathbb{1} & \xrightarrow{\beta'_V} & V^\vee \otimes V \\
b_V \downarrow & & \uparrow \varphi_V^{-1} \otimes \text{id}_V \\
V \otimes V^\vee & \xrightarrow{(c_{V^\vee, V})^{-1}} & V^\vee \otimes V
\end{array}
\quad
\begin{array}{ccc}
V \otimes V^\vee & \xrightarrow{\delta'_V} & \mathbb{1} \\
\downarrow \text{id}_V \otimes \varphi_V & & \uparrow d_V \\
V \otimes V^\vee & \xrightarrow{c_{V, V^\vee}} & V^\vee \otimes V
\end{array}
\quad (3.60)$$

Compare with equation (3.6). These diagrams are required to be compatible with *each other* as well, hence we must be careful to always check that the Type I restriction lemma (3.29) is satisfied (this enforces extra conditions on φ_V).

Adding rigidity to Type II dagger balanced strict monoidal categories (definition (3.53)) is similar:

Definition 3.61. A **Type II dagger balanced rigid strict monoidal category** is a dagger strict monoidal category equipped with rigidity and balancing. The rigidity must satisfy

$$V^\vee = V^* \quad \beta'_V = (d_V)^\dagger \quad \delta'_V = (b_V)^\dagger \quad (3.62)$$

The family of natural braiding isomorphisms must satisfy a **non-unitary** condition:

$$(c_{V, W})^\dagger = c_{W, V} \quad \text{non-unitary} \quad (3.63)$$

The family of natural twist isomorphisms must be **self-adjoint**:

$$(\theta_V)^\dagger = \theta_V \quad \text{self-adjoint} \quad (3.64)$$

Finally we require that the braiding and rigidity must be compatible up to a natural family of unique isomorphisms φ_V . This is equivalent to forcing the following diagrams to commute:

$$\begin{array}{ccc}
\mathbb{1} & \xrightarrow{\beta'_V} & V^\vee \otimes V \\
b_V \downarrow & & \uparrow \varphi_V^{-1} \otimes \text{id}_V \\
V \otimes V^\vee & \xrightarrow{(c_{V^\vee, V})^{-1}} & V^\vee \otimes V
\end{array}
\quad
\begin{array}{ccc}
V \otimes V^\vee & \xrightarrow{\delta'_V} & \mathbb{1} \\
\downarrow \text{id}_V \otimes \varphi_V & & \uparrow d_V \\
V \otimes V^\vee & \xrightarrow{c_{V, V^\vee}} & V^\vee \otimes V
\end{array}
\quad (3.65)$$

Compare with equation (3.6). These diagrams are required to be compatible with *each other* as well, hence we must be careful to always check that the Type II restriction lemma (3.39) is satisfied (this enforces extra conditions on φ_V).

Dagger ribbon categories

Starting with right-rigidity alone we have seen that both braided right-rigid and dagger right-rigid structures provide “for free” left rigidity. These two canonical left-rigidity structures are related by a family of unique isomorphisms φ_V as in proposition (2.29). Since in both cases we have $V^\vee = V^*$ we no longer distinguish them. Hence **from now on we only use the notation V^*** .

The following definition is well-documented (see e.g. [Tur94] II.5):

Definition 3.66. A **Hermitian ribbon category** (which we also call a **Type I dagger ribbon category** to correspond with our previous nomenclature) is a ribbon category that in addition is a dagger strict monoidal category. The ribbon and dagger are required to be compatible according to the following equations and commutative diagrams:

$$\begin{aligned} (c_{V,W})^\dagger &= (c_{V,W})^{-1} \quad (\text{unitarity}) \\ (\theta_V)^\dagger &= (\theta_V)^{-1} \quad (\text{unitarity}) \end{aligned} \tag{3.67}$$

$$\begin{array}{ccc} \mathbb{1} & \xrightarrow{(d_V)^\dagger} & V^* \otimes V \\ b_V \downarrow & & \uparrow \text{id}_{V^*} \otimes \theta_V^{-1} \\ V \otimes V^* & \xrightarrow{(c_{V^*,V})^{-1}} & V^* \otimes V \end{array} \quad \begin{array}{ccc} V \otimes V^* & \xrightarrow{(b_V)^\dagger} & \mathbb{1} \\ \downarrow \theta_V \otimes \text{id}_{V^*} & & \uparrow d_V \\ V \otimes V^* & \xrightarrow{c_{V,V^*}} & V^* \otimes V \end{array} \tag{3.68}$$

As a verification that our previous definitions are correct generalizations of Hermitian ribbon categories we note the following fact:

Proposition 3.69. *A category \mathcal{V} is a Type I dagger ribbon category if and only if it is a Type I dagger balanced rigid strict monoidal category such that $\varphi_V = \theta_{V^*}$.*

Proof. First suppose that \mathcal{V} is a Type I dagger ribbon category. We show first that the commutative diagrams in equation (3.68) can be cast in the

form of the diagrams in equation (3.60). First use naturality of c to rewrite equation (3.68) as

$$\begin{aligned}(d_V)^\dagger &= (c_{V^*,V})^{-1} \circ (\theta_V^{-1} \otimes \text{id}_{V^*}) \circ b_V \\ (b_V)^\dagger &= d_V \circ (\text{id}_{V^*} \otimes \theta_V) \circ c_{V,V^*}\end{aligned}\tag{3.70}$$

Now we use the ribbon condition to rewrite this as

$$\begin{aligned}(d_V)^\dagger &= (c_{V^*,V})^{-1} \circ (\text{id}_V \otimes \theta_{V^*}^{-1}) \circ b_V \\ (b_V)^\dagger &= d_V \circ (\theta_{V^*} \otimes \text{id}_V) \circ c_{V,V^*}\end{aligned}\tag{3.71}$$

Finally we use naturality of c again and identify $\varphi_V = \theta_{V^*}$ (this identification is unjustified for now)

$$\begin{aligned}(d_V)^\dagger &= (\varphi_V^{-1} \otimes \text{id}_V) \circ (c_{V^*,V})^{-1} \circ b_V \\ (b_V)^\dagger &= d_V \circ c_{V,V^*} \circ (\text{id}_V \otimes \varphi_V)\end{aligned}\tag{3.72}$$

This is clearly of the form in equation (3.60).

To justify the identification we must show that $\varphi_V = \theta_{V^*}$ satisfies the Type I restriction lemma (3.29). By uniqueness of φ_V this shows that the family of twist isomorphisms θ_{V^*} is the unique family that relates the two left rigidity structures. We then conclude that \mathcal{V} is a Type I dagger balanced rigid strict monoidal category such that $\varphi_V = \theta_{V^*}$.

Let us verify the first Type I restriction (the other is similar). For convenience we copy the restrictions down again, substituting $\varphi_V = \theta_{V^*}$ and unitarity $(\theta_V)^\dagger = (\theta_V)^{-1}$

$$\begin{aligned}d_V \circ (\theta_{V^*}^{-1} \otimes \text{id}_V) \circ c_{V^*,V}^{-1} &\stackrel{?}{=} d_V \circ (\theta_{V^*} \otimes \text{id}_V) \circ c_{V,V^*} \\ c_{V^*,V}^{-1} \circ (\text{id}_V \otimes \theta_{V^*}^{-1}) \circ b_V &\stackrel{?}{=} c_{V,V^*} \circ (\text{id}_V \otimes \theta_{V^*}) \circ b_V\end{aligned}\tag{3.73}$$

The LHS can be shown to be equal to the RHS by using special cases of balancing as well as naturality of θ and c :

$$\theta_{V^* \otimes V} = c_{V,V^*} \circ c_{V^*,V} \circ (\theta_{V^*} \otimes \theta_V)\tag{3.74}$$

becomes

$$(\theta_{V^*}^{-1} \otimes \text{id}_V) = \theta_{V^* \otimes V}^{-1} \circ c_{V,V^*} \circ c_{V^*,V} \circ (\text{id}_{V^*} \otimes \theta_V)\tag{3.75}$$

Now by naturality of c this becomes

$$(\theta_{V^*}^{-1} \otimes \text{id}_V) = \theta_{V^* \otimes V}^{-1} \circ (\text{id}_{V^*} \otimes \theta_V) \circ c_{V,V^*} \circ c_{V^*,V}\tag{3.76}$$

Finally we have

$$(\theta_{V^*}^{-1} \otimes \text{id}_V) \circ c_{V^*,V}^{-1} = \theta_{V^* \otimes V}^{-1} \circ (\text{id}_{V^*} \otimes \theta_V) \circ c_{V,V^*} \quad (3.77)$$

Composing with d_V we obtain

$$d_V \circ (\theta_{V^*}^{-1} \otimes \text{id}_V) \circ c_{V^*,V}^{-1} = d_V \circ \theta_{V^* \otimes V}^{-1} \circ (\text{id}_{V^*} \otimes \theta_V) \circ c_{V,V^*} \quad (3.78)$$

Now by naturality of θ we have $d_V \circ \theta_{V^* \otimes V}^{-1} = \theta_1^{-1} \circ d_V = d_V$. So we have

$$d_V \circ (\theta_{V^*}^{-1} \otimes \text{id}_V) \circ c_{V^*,V}^{-1} = d_V \circ (\text{id}_{V^*} \otimes \theta_V) \circ c_{V,V^*} \quad (3.79)$$

Finally using the ribbon condition in definition (2.128) this becomes

$$d_V \circ (\theta_{V^*}^{-1} \otimes \text{id}_V) \circ c_{V^*,V}^{-1} = d_V \circ (\theta_{V^*} \otimes \text{id}_V) \circ c_{V,V^*} \quad (3.80)$$

which verifies the first restriction. The second restriction is similar.

Conversely, suppose that \mathcal{V} is a Type I dagger balanced rigid strict monoidal category such that $\varphi_V = \theta_{V^*}$. We substitute the unitary condition $(\theta_V)^\dagger = (\theta_V)^{-1}$ into the Type I restriction lemma

$$\begin{aligned} d_V \circ (\theta_{V^*}^{-1} \otimes \text{id}_V) \circ c_{V^*,V}^{-1} &= d_V \circ (\theta_{V^*} \otimes \text{id}_V) \circ c_{V,V^*} & (3.81) \\ c_{V^*,V}^{-1} \circ (\text{id}_V \otimes \theta_{V^*}^{-1}) \circ b_V &= c_{V,V^*} \circ (\text{id}_V \otimes \theta_{V^*}) \circ b_V \end{aligned}$$

Concentrating on the first restriction and using the identical balancing argument as before we obtain

$$d_V \circ (\theta_{V^*}^{-1} \otimes \text{id}_V) \circ c_{V^*,V}^{-1} = d_V \circ (\text{id}_{V^*} \otimes \theta_V) \circ c_{V,V^*} \quad (3.82)$$

Combining this with the first restriction we obtain

$$d_V \circ (\theta_{V^*} \otimes \text{id}_V) \circ c_{V,V^*} = d_V \circ (\text{id}_{V^*} \otimes \theta_V) \circ c_{V,V^*} \quad (3.83)$$

Cancelling the isomorphism c_{V,V^*} we obtain

$$d_V \circ (\theta_{V^*} \otimes \text{id}_V) = d_V \circ (\text{id}_{V^*} \otimes \theta_V) \quad (3.84)$$

which shows that \mathcal{V} is ribbon. Reversing the steps in the beginning of the proof we can cast the diagrams in equation (3.60) into diagrams like those in equation (3.68). Hence \mathcal{V} is a Type I dagger ribbon category. \square

Definition 3.85. A **Type II dagger ribbon category** is a ribbon category that in addition is a dagger strict monoidal category. The ribbon and dagger are required to be compatible according to the following equations and commutative diagrams:

$$\begin{aligned} (c_{V,W})^\dagger &= c_{W,V} \quad (\text{non-unitary}) \\ (\theta_V)^\dagger &= \theta_V \quad (\text{self-adjoint}) \end{aligned} \tag{3.86}$$

$$\begin{array}{ccc} \mathbb{1} & \xrightarrow{(d_V)^\dagger} & V^* \otimes V \\ b_V \downarrow & & \uparrow \text{id}_{V^*} \otimes \theta_V^{-1} \\ V \otimes V^* & \xrightarrow{(c_{V^*,V})^{-1}} & V^* \otimes V \end{array} \quad \begin{array}{ccc} V \otimes V^* & \xrightarrow{(b_V)^\dagger} & \mathbb{1} \\ \downarrow \theta_V \otimes \text{id}_{V^*} & & \uparrow d_V \\ V \otimes V^* & \xrightarrow{c_{V,V^*}} & V^* \otimes V \end{array} \tag{3.87}$$

For Type II categories we do *not* have an equivalence between Type II dagger ribbon categories and Type II dagger balanced rigid strict monoidal categories such that $\varphi_V = \theta_{V^*}$. Instead the ribbon condition is stronger:

Proposition 3.88. *Let \mathcal{V} be a Type II dagger ribbon category. Then \mathcal{V} is a Type II dagger balanced rigid strict monoidal category such that $\varphi_V = \theta_{V^*}$.*

Proof. Given that \mathcal{V} is a Type II dagger ribbon category it is easy to show that the Type II restriction lemma (3.39) is satisfied by $\varphi_V = \theta_{V^*}$ (using self-adjointness $(\theta_V)^\dagger = \theta_V$).

On the other hand suppose that \mathcal{V} is a Type II dagger balanced rigid strict monoidal category such that $\varphi_V = \theta_{V^*}$. Unfortunately the Type II restrictions are *not* strong enough to conclude that \mathcal{V} is ribbon. \square

4 Partial traces and dagger structures

As mentioned in [AC08] the ordinary (Hilbert-space) partial trace plays a fundamental role in quantum mechanics and quantum information, hence the generalization to category theory due to Joyal, Street, and Verity [JSV96] (discussed briefly in section (2)) deserves further study. Guided by our overall philosophy in this paper we maintain more generality than the canonical trace for *ribbon* categories that is usually studied in other literature. This section is meant to prepare for further interpretation (concerning quantum information) in forthcoming work.

Because the categorical partial trace [JSV96] is formulated for categories that are *at least* balanced, and since we already have argued in section (2) that rigidity is the minimal structure necessary for the Abramsky-Coecke *quantum information flow* paradigm, we restrict our attention to balanced right-rigid strict monoidal categories (in this case we already described three canonical notions of partial trace in figure (31)).

The chief purpose of this short section is to study the interactions between the Vanilla, GoofyUp, and GoofyDown partial traces ($\text{tr}_{\text{vanilla}}$, $\text{tr}_{\text{goofUp}}$, and $\text{tr}_{\text{goofDn}}$) when the dagger structures from section (3) are applied. ³⁶

Goofy traces and tricks

First we outline a fact and a lemma (neither of which refers to dagger structures).

Fact 4.1. *Let \mathcal{V} be a balanced right-rigid strict monoidal category. Let $f : A \otimes V \rightarrow B \otimes V$ be a morphism in \mathcal{V} . Then*

$$\text{tr}_{\text{goofDn}}^{V;A,B}(f) = \text{tr}_{\text{goofUp}}^{V;A,B}((\text{id}_B \otimes \theta_V^{-1}) \circ f \circ (\text{id}_A \otimes \theta_V)) \quad (4.2)$$

where θ denotes the family of natural twist isomorphisms.

Proof. The graphical proof is transparent and is presented in figure (37). \square

The following lemma shows that under some circumstances we can exchange overcrossings for undercrossings by manipulating the twists appropriately. ³⁷ We note that a ribbon condition is neither necessary nor used in this proof.

Lemma 4.3. *Let \mathcal{V} be a balanced right-rigid strict monoidal category. Then the moves depicted in figure (38) are valid.*

Proof. We first prove the moves involving the death morphisms. Balancing implies

$$\theta_{V^* \otimes V} = c_{V,V^*} \circ c_{V^*,V} \circ (\theta_{V^*} \otimes \theta_V) \quad (4.4)$$

³⁶For ribbon categories the results in this section reduce to $(\text{tr}_q(f))^\dagger = \text{tr}_q(f^\dagger)$.

³⁷This is the reason that we resisted studying undercrossed versions of the partial traces in figure (31) since we would obtain nothing new.

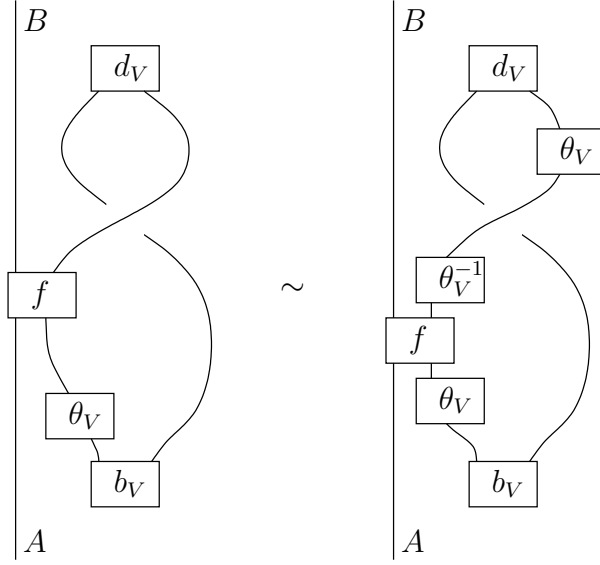

Figure 37: $\text{tr}_{\text{goofDn}}^{V;A,B}(f) = \text{tr}_{\text{goofUp}}^{V;A,B}((\text{id}_B \otimes \theta_V^{-1}) \circ f \circ (\text{id}_A \otimes \theta_V))$

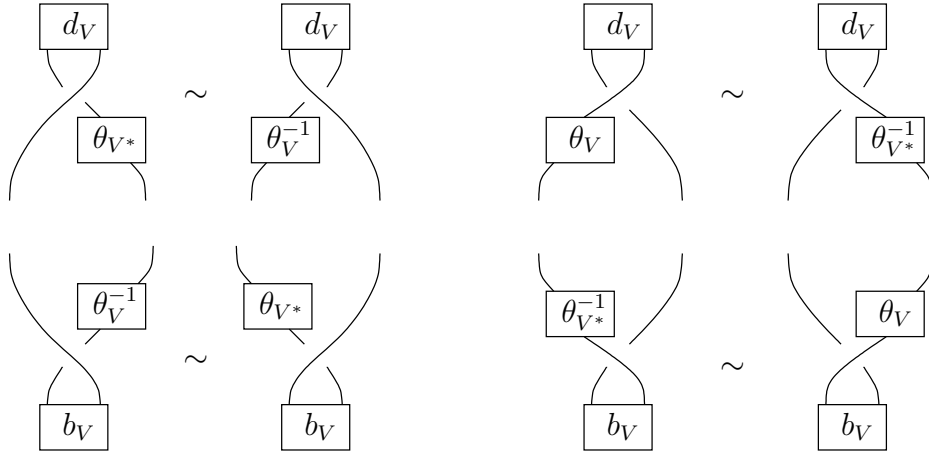

Figure 38: These moves are allowed in a balanced right-rigid strict monoidal category

Composing with d_V on the left of both sides and using naturality of θ ($d_V \circ \theta_{V^* \otimes V} = \theta_{\mathbb{1}} \circ d_V = d_V$) we obtain

$$d_V = d_V \circ c_{V,V^*} \circ c_{V^*,V} \circ (\theta_{V^*} \otimes \theta_V) \quad (4.5)$$

Using the naturality of c and rearranging we have

$$d_V \circ (c_{V^*,V})^{-1} = d_V \circ c_{V,V^*} \circ (\theta_V \otimes \theta_{V^*}) \quad (4.6)$$

This can be rearranged in two different ways, yielding the top moves in figure (38)

$$\begin{aligned} d_V \circ (c_{V^*,V})^{-1} \circ (\theta_V^{-1} \otimes \text{id}_{V^*}) &= d_V \circ c_{V,V^*} \circ (\text{id}_V \otimes \theta_{V^*}) \\ d_V \circ (c_{V^*,V})^{-1} \circ (\text{id}_V \otimes \theta_{V^*}^{-1}) &= d_V \circ c_{V,V^*} \circ (\theta_V \otimes \text{id}_{V^*}) \end{aligned} \quad (4.7)$$

The moves involving the birth morphisms can be similarly obtained by composing with b_V on the *right* using a different balancing condition

$$\theta_{V \otimes V^*} = c_{V^*,V} \circ c_{V,V^*} \circ (\theta_V \otimes \theta_{V^*}) \quad (4.8)$$

□

Type I partial traces

Theorem 4.9. *Let \mathcal{V} be a Type I **dagger** balanced right-rigid strict monoidal category as in definition (3.56). Let $f : A \otimes V \rightarrow B \otimes V$ be a morphism in \mathcal{V} . Then the following are true:*

$$\text{tr}_{\text{goofUp}}^{V;A,B}(f) = \text{tr}_{\text{goofDn}}^{V;A,B}(f) =: \text{tr}_{\text{goofy}}^{V;A,B}(f) \quad (4.10)$$

$$\left(\text{tr}_{\text{vanilla}}^{V;A,B}(f) \right)^\dagger = \text{tr}_{\text{goofy}}^{V;A,B}(f^\dagger) \quad (4.11)$$

$$\left(\text{tr}_{\text{goofy}}^{V;A,B}(f) \right)^\dagger = \text{tr}_{\text{vanilla}}^{V;A,B}(f^\dagger) \quad (4.12)$$

Proof. The proof relies on the involutivity $()^\dagger \dagger = ()$ of the dagger as well as the following three statements (most easily shown using the graphical calculus)

$$\left(\text{tr}_{\text{vanilla}}^{V;A,B}(f) \right)^\dagger = \text{tr}_{\text{goofDn}}^{V;A,B}(f^\dagger) \quad (4.13)$$

$$\left(\text{tr}_{\text{goofUp}}^{V;A,B}(f) \right)^\dagger = \text{tr}_{\text{vanilla}}^{V;A,B}(f^\dagger)$$

$$\left(\text{tr}_{\text{goofDn}}^{V;A,B}(f) \right)^\dagger = \text{tr}_{\text{vanilla}}^{V;A,B}(f^\dagger)$$

For completeness we give algebraic arguments to show the first statement. Consider the Vanilla partial trace in figure (31):

$$\begin{aligned} \mathrm{tr}_{\mathrm{vanilla}}^{V;A,B}(f) = & \\ & (\mathrm{id}_B \otimes d_V) \circ (\mathrm{id}_B \otimes \theta_{V^*} \otimes \mathrm{id}_V) \circ (\mathrm{id}_B \otimes c_{V,V^*}) \circ (f \otimes \mathrm{id}_{V^*}) \circ (\mathrm{id}_A \otimes b_V) \end{aligned} \quad (4.14)$$

Now take the dagger of both sides. We use the facts that for a Type I dagger balanced rigid strict monoidal category we have $(d_V)^\dagger = \beta_V$, $(b_V)^\dagger = \delta_V$, $(\theta_{V^*})^\dagger = (\theta_{V^*})^{-1}$, and $(c_{V,V^*})^\dagger = (c_{V,V^*})^{-1}$

$$\begin{aligned} \left(\mathrm{tr}_{\mathrm{vanilla}}^{V;A,B}(f) \right)^\dagger = & (\mathrm{id}_A \otimes \delta_V) \circ (f^\dagger \otimes \mathrm{id}_{V^*}) \circ (\mathrm{id}_B \otimes c_{V,V^*}^{-1}) \\ & \circ (\mathrm{id}_B \otimes \theta_{V^*}^{-1} \otimes \mathrm{id}_V) \circ (\mathrm{id}_B \otimes \beta_V) \end{aligned} \quad (4.15)$$

Now we use the commutative diagrams in equation (3.60) to rewrite the composition on the RHS as

$$\begin{aligned} & (\mathrm{id}_A \otimes d_V) \circ (\mathrm{id}_A \otimes c_{V,V^*}) \circ (\mathrm{id}_A \otimes \mathrm{id}_V \otimes \varphi_V) \\ & \circ (f^\dagger \otimes \mathrm{id}_{V^*}) \circ (\mathrm{id}_B \otimes c_{V,V^*}^{-1}) \circ (\mathrm{id}_B \otimes \theta_{V^*}^{-1} \otimes \mathrm{id}_V) \\ & \circ (\mathrm{id}_B \otimes \varphi_V^{-1} \otimes \mathrm{id}_V) \circ (\mathrm{id}_B \otimes c_{V^*,V}^{-1}) \circ (\mathrm{id}_B \otimes b_V) \end{aligned} \quad (4.16)$$

Now since $\theta_{V^*}^{-1}$ is natural we can commute φ_V^{-1} past it. In addition the braiding c_{V,V^*}^{-1} is natural hence we can commute it with φ_V^{-1} as well. Then the isomorphisms φ_V and φ_V^{-1} cancel each other, leaving us with

$$\begin{aligned} & (\mathrm{id}_A \otimes d_V) \circ (\mathrm{id}_A \otimes c_{V,V^*}) \circ (\mathrm{id}_A \otimes \mathrm{id}_V \otimes \mathrm{id}_{V^*}) \\ & \circ (f^\dagger \otimes \mathrm{id}_{V^*}) \circ (\mathrm{id}_B \otimes c_{V,V^*}^{-1}) \circ (\mathrm{id}_B \otimes \theta_{V^*}^{-1} \otimes \mathrm{id}_V) \\ & \circ (\mathrm{id}_B \otimes \mathrm{id}_{V^*} \otimes \mathrm{id}_V) \circ (\mathrm{id}_B \otimes c_{V^*,V}^{-1}) \circ (\mathrm{id}_B \otimes b_V) \end{aligned} \quad (4.17)$$

or more simply

$$\begin{aligned} & (\mathrm{id}_A \otimes d_V) \circ (\mathrm{id}_A \otimes c_{V,V^*}) \\ & \circ (f^\dagger \otimes \mathrm{id}_{V^*}) \circ (\mathrm{id}_B \otimes c_{V,V^*}^{-1}) \circ (\mathrm{id}_B \otimes \theta_{V^*}^{-1} \otimes \mathrm{id}_V) \\ & \circ (\mathrm{id}_B \otimes c_{V^*,V}^{-1}) \circ (\mathrm{id}_B \otimes b_V) \end{aligned} \quad (4.18)$$

Now we use one of the tricks in lemma (4.3) (lower right corner of figure (38)) to rewrite this as

$$\begin{aligned}
& (\text{id}_A \otimes d_V) \circ (\text{id}_A \otimes c_{V,V^*}) \\
& \quad \circ (f^\dagger \otimes \text{id}_{V^*}) \circ (\text{id}_B \otimes c_{V,V^*}^{-1}) \circ (\text{id}_B \otimes \text{id}_{V^*} \otimes \theta_V) \\
& \quad \quad \quad \circ (\text{id}_B \otimes c_{V,V^*}) \circ (\text{id}_B \otimes b_V) \quad (4.19)
\end{aligned}$$

We commute θ_V past c_{V,V^*}^{-1} by naturality of the braiding. Then c_{V,V^*}^{-1} and c_{V,V^*} cancel each other

$$\begin{aligned}
& (\text{id}_A \otimes d_V) \circ (\text{id}_A \otimes c_{V,V^*}) \\
& \quad \circ (f^\dagger \otimes \text{id}_{V^*}) \circ (\text{id}_B \otimes \theta_V \otimes \text{id}_{V^*}) \circ (\text{id}_B \otimes b_V) \quad (4.20)
\end{aligned}$$

Comparing with figure (31) this is just $\text{tr}_{\text{goofDn}}(f^\dagger)$. Hence we conclude

$$\left(\text{tr}_{\text{vanilla}}^{V;A,B}(f) \right)^\dagger = \text{tr}_{\text{goofDn}}(f^\dagger) \quad (4.21)$$

The other two statements in equation (4.13) follow using similar arguments (again we recommend the graphical calculus here). We note that the Type I restriction lemma (3.29) (both parts) must be used to show the third statement.

To conclude the proof we note that by equation (4.13) and $()^{\dagger\dagger} = ()$

$$\begin{aligned}
\text{tr}_{\text{goofUp}}^{V;A,B}(f) &= \quad (4.22) \\
&= \left(\text{tr}_{\text{goofUp}}^{V;A,B}(f) \right)^{\dagger\dagger} \\
&= \left(\text{tr}_{\text{vanilla}}^{V;A,B}(f^\dagger) \right)^\dagger \\
&= \left(\text{tr}_{\text{goofDn}}^{V;A,B}(f) \right)^{\dagger\dagger} \\
&= \text{tr}_{\text{goofDn}}^{V;A,B}(f)
\end{aligned}$$

□

Since the Goofy partial traces are equivalent in Type I theories we have the following corollary:

Corollary 4.23. *Let \mathcal{V} be a Type I **dagger** balanced right-rigid strict monoidal category as in definition (3.56). Let $f : A \otimes V \rightarrow B \otimes V$ be a morphism in \mathcal{V} . Then the Goofy partial trace is “partial cyclic” with respect to the twist isomorphisms:*

$$\begin{aligned} tr_{goofy}^{V;A,B}(f) &= & (4.24) \\ &= tr_{goofy}^{V;A,B}((id_B \otimes \theta_V^{-1}) \circ f \circ (id_A \otimes \theta_V)) \\ &= tr_{goofy}^{V;A,B}((id_B \otimes \theta_V) \circ f \circ (id_A \otimes \theta_V^{-1})) \end{aligned}$$

Proof. Use fact (4.1). □

Type II partial traces

For Type II dagger balanced rigid strict monoidal categories the dagger does *not equate* the GoofyUp with the GoofyDown partial trace. Furthermore there is no dagger relationship between the Vanilla partial trace and the Goofy partial traces.

Theorem 4.25. *Let \mathcal{V} be a Type II **dagger** balanced right-rigid strict monoidal category as in definition (3.61). Let $f : A \otimes V \rightarrow B \otimes V$ be a morphism in \mathcal{V} . Then the following are true:*

$$\begin{aligned} \left(tr_{goofUp}^{V;A,B}(f) \right)^\dagger &= tr_{goofDn}^{V;A,B}(f^\dagger) & (4.26) \\ \left(tr_{goofDn}^{V;A,B}(f) \right)^\dagger &= tr_{goofUp}^{V;A,B}(f^\dagger) \\ \left(tr_{vanilla}^{V;A,B}(f) \right)^\dagger &= tr_{vanilla}^{V;A,B}(f^\dagger) \end{aligned}$$

Proof. Similar to the proof of theorem (4.9) except the Type II dagger action must be used (or, graphically, the Type II graphical dagger action). Furthermore we must use self-adjointness $(\theta_V)^\dagger = \theta_V$ and non-unitarity $(c_{V,W})^\dagger = c_{W,V}$. □

5 Acknowledgements

During this work SDS was supported jointly by the Department of Mathematics and the Department of Physics and Astronomy at the University of Utah. The work of YSW is partially supported by US NSF through Grant No. PHY-0756958.

References

- [AC08] Samson Abramsky and Bob Coecke. Categorical Quantum Mechanics. In *Handbook of Quantum Logic and Quantum Structures vol II*. Elsevier, 2008. Found at arXiv:0808.1023v1.
- [Ati90] M. Atiyah. *The geometry and physics of knots*. Cambridge University Press, 1990.
- [BK00] B. Bakalov and A. Kirillov. *Lectures on Tensor Categories and Modular Functor*. University Lecture Series. American Mathematical Society, 2000. Also available online at <http://www.math.sunysb.edu/~kirillov/tensor/tensor.html>.
- [BZ06] B. A. Bernevig and S.C. Zhang. Quantum Spin Hall Effect. *Phys. Rev. Lett.* **96**, 106802, 2006.
- [Dir82] Paul A. M. Dirac. *The Principles of Quantum Mechanics, 4th Ed.* Oxford University Press, 1982.
- [FHLT09] Daniel S. Freed, Michael J. Hopkins, Jacob Lurie, and Constantin Teleman. Topological quantum field theories from compact Lie groups. *arXiv:0905.0731*, 2009.
- [FKM07] Liang Fu, C.L. Kane, and E.J. Mele. Topological insulators in 3 dimensions. *Phys. Rev. Lett.* **98** 106803, 2007.
- [FY89] P. Freyd and D. Yetter. Braided compact closed categories with applications to low dimensional topology. *Adv. in Math.* **77** 156-182, 1989.
- [FY92] P. Freyd and D. Yetter. Coherence theorems via knot theory. *J. Pure Appl. Algebra* **78** 49-76, 1992.
- [Jai07] Jainendra Jain. *Composite Fermions*. Cambridge University Press, 2007.
- [JS88] André Joyal and Ross Street. Planar Diagrams and Tensor Algebra. *unpublished paper*, 1988.
- [JS91a] André Joyal and Ross Street. Geometry of Tensor Calculus I. *Advances in Math.* **88**, 55-113, 1991.

- [JS91b] André Joyal and Ross Street. Geometry of Tensor Calculus II. *unpublished incomplete paper*, 1991.
- [JS93] André Joyal and Ross Street. Braided Tensor Categories. *Adv. Math.* **102**, 20-78, 1993.
- [JSV96] Joyal, Street, and Verity. Traced monoidal categories. *Proc. of the Cambridge Phil. Soc.* **119**, 447-468, 1996. See also an extension by Amy Young available on Ross Street's webpage.
- [Kas95] C. Kassel. *Quantum Groups*. Graduate Texts in Mathematics. Springer-Verlag, 1995.
- [Kit03] A. Kitaev. Fault-tolerant Quantum Computation by Anyons. *Annals Phys.* **303**, 2003.
- [KL80] G.M. Kelly and M.L. Laplaza. Coherence for compact closed categories. *J. Pure App. Algebra* **19** 193-213, 1980.
- [KM05] C.L. Kane and E.J. Mele. Quantum spin Hall effect in graphene. *Phys. Rev. Lett.* **95** 226801, 2005.
- [Mac04] George W. Mackey. *Mathematical Foundations of Quantum Mechanics*. Dover, 2004.
- [RT90] N. Yu Reshetikhin and V.G. Turaev. Ribbon Graphs and Their Invariants Derived from Quantum Groups. *Commun. Math. Phys.* **127**, 1-26, 1990.
- [RT91] N. Yu Reshetikhin and V.G. Turaev. Invariants of 3-manifolds via link polynomials and quantum groups. *Invent. Math.* **103**, 547-597, 1991.
- [Sel07] P. Selinger. Dagger compact categories and completely positive maps. *Electronic Notes in Theoretical Computer Science* **170** 139-163, 2007. Extended version in Structures of Physics, B. Coecke (ed), Springer Lecture Notes in Physics 2007.
- [SFN⁺07] Sankar Das Sarma, Michael Freedman, Chetan Nayak, Steven H. Simon, and Ady Stern. Non-abelian anyons and topological quantum computation. *arXiv:0707.1889v1*, 2007.

- [Sti08] Spencer D. Stirling. Abelian Chern-Simons theory with toral gauge group, modular tensor categories, and group categories. *arXiv:0807.2857*, 2008.
- [Tur94] V.G. Turaev. *Quantum Invariants of Knots and 3-Manifolds*. Studies in Mathematics. de Gruyter, 1994.
- [vN96] John von Neumann. *Mathematical Foundations of Quantum Mechanics (English translation)*. Princeton University Press, 1996.
- [Wu84] Yong-Shi Wu. General Theory of Quantum Statistics in Two Dimensions. *Phys. Rev. Lett.* **51**, 2101, 1984.